

USE AND MAINTENANCE MANUAL



PRECISION AIR CONDITIONING UNITS WITH
DIRECT EXPANSION FOR TELECOM
APPLICATION

ED.P-A SF (Free-cooling System)

TABLE OF CONTENTS

1	INTRODUCTION	Pag. 2
1.1	Manual content	Pag. 2
1.2	Safety marks	Pag. 2
1.3	Referring standards	Pag. 2
1.4	Warranty	Pag. 3
1.5	Readers of the Manual	Pag. 3
2	MAIN SAFETY RULES	Pag. 3
2.1	Main warnings	Pag. 3
2.2	Allowed use	Pag. 3
2.3	Forbidden use	Pag. 3
2.4	Dangerous areas	Pag. 4
3	GENERAL DESCRIPTION	Pag. 4
3.1	Unit description.....	Pag. 4
3.2	Main components	Pag. 9
3.2.1	Cooling circuits	Pag. 10
3.3	Specification	Pag. 13
3.4	Dimensional drawings	Pag. 13
3.5	Accessories	Pag. 13
4	INSTALLATION	Pag. 14
4.1	Identification tag	Pag. 14
4.2	Reception and inspection	Pag. 14
4.3	Handling	Pag. 15
4.4	Arrangements and placing	Pag. 16
4.5	Cooling connections (ED.A.)	Pag. 20
4.6	Condensate drain connection	Pag. 21
4.7	Air connections	Pag. 21
4.7.1	Mounting.....	Pag. 21
4.7.2	Duct minimum dimensions	Pag. 21
4.8	Electric connections	Pag. 22
4.8.1	Power supply connection	Pag. 23
4.8.2	Cconnection to the user terminal board	Pag. 23
4.8.3	Warning in case of connection to the terminal board when optional "TE" is installed	Pag. 24
4.8.4	Condenser connections (ED.A)	Pag. 24
4.9	System vacuum and charge execution (ED.A.)	Pag. 24
4.9.1	General warnings	Pag. 24
4.9.2	Vacuum execution	Pag. 25
4.9.3	Refrigerant charge execution	Pag. 26
5	OPERATION	Pag. 28
5.1	First startup	Pag. 28
5.1.1	Cooling circuit (ED.A.)	Pag. 28
5.1.2	Startup	Pag. 28
5.1.3	Setup	Pag. 29
5.1.4	Microprocessor setting	Pag. 30
5.1.5	Steam production setting (unit with humidifier)	Pag. 30
5.2	Troubleshooting	Pag. 30
5.3	Common troubles	Pag. 31
5.4	Routine maintenance	Pag. 33
6	DISMANTLING	Pag. 33
	AIR CONDENSER	Pag. 34

The manufacturer reserves the right to modify this manual without any prior notice

1 - INTRODUCTION

1.1 Manual content

The present handbook, originally written in Italian, was completed in compliance with the "Machinery Directive". It contains all the necessary information for carrying out without any risk transportation, installation, startup, operation, setting, maintenance and dismantling of the air conditioning unit of ED Millennium series.

Should you have any doubt on the correct understanding of these instructions, please contact the Manufacturer in order to get further explanations.

1.2 Safety marks

The following safety marks are used in this manual to draw attention to all useful information in order to avoid any dangerous situation which could be unsafe and harmful for people, could damage equipment and environment besides breaking the unit.



It means operation and behaviour not allowed.



It means danger or risk to people, things or environment.



It means an electrical danger.



It means a warning about important functions or useful information. Pay the maximum attention to the paragraphs marked with this symbol.

1.3 Referring standards

The units of the 'ED' series are designed and manufactured in compliance with the relevant European Directives and in particular, they meet the "Essential Safety Requirements" as set out in the European Directive 89/392/CEE, and further amendments, as attested by the CE mark that is on each unit.

As a matter of fact, the units are certified by the manufacturer and are provided together with the CE Declaration of Conformity which is attached to the present manual.

Where applicable, the units mentioned in this handbook are in conformity with the directive 97/23/CE (PED), concerning the pressure devices.

1.4 Warranty

The manufacturer warrants the Air Conditioning Units according to what stated on his general sales terms or according to what else explicitly agreed.

The Manufacturer Warranty is void in case the guidance of this manual has not been carefully respected.

The manufacturer refuses all responsibility for any damage to people, animals, things or environment, caused by incorrect installation, maintenance or setting or misuse of the machine. It is considered as "misuse" of the machine any use not explicitly allowed in this manual.



Warning: on the first startup, duly fill in the relevant report attached to this manual and send a copy to Emicon A.C. (Customer Service), in order to make the warranty valid.

1.5 Readers of the Manual

This manual and all its attachments are supplied with the described unit. The manual must be kept by the machine's owner in a proper place. To this end, a plastic bag where to store the manual has been placed inside the machine so that it can be always easily accessible for consultation and at the same time, it can be preserved in a good state.

In case the manual is lost or deteriorated, a new copy must be requested directly to the manufacturer.

2 - MAIN SAFETY RULES

2.1 General warnings

 Read carefully the whole handbook before performing any operation on the unit. Only qualified and trained technicians must perform any operation on the machine.

 Do not touch the machine if with bare feet or with humid or wet parts of the body.
Do not perform any cleaning operation before the main switch is "OFF" and power line disconnected.
Do not spread, leave unattended or to the reach of children any packaging material (carton box, staples, plastic bags, etc.) as they may be a source of danger.

2.2 Allowed use

The machine has been designed and produced for air conditioning of technology centres and therefore it must be used only for this purpose, according to its performing features. All different uses are not allowed and disclaim all manufacturer's responsibility for damages caused to environment, people, animals and properties.

2.3 Forbidden use

Do not use the machine:

- Ø for other use than that described in paragraph 2.2;
- Ø when it is exposed to rainfall;
- Ø in atmosphere with high risk of fire or explosion;
- Ø in spaces with corrosive atmosphere.



Any operation on the unit must be carried out in compliance with local technical standards.

2.4 Dangerous areas

The machine is closed by case panels, at the exception of the upper part on some models. The dangerous parts inside the unit are not accessible from outside.



Only qualified and trained personnel is allowed to remove the covering panels because inside the unit there are parts with high risk of electric shock, areas with high temperature and working mechanical components.



If the machine is supplied with the cooling circuit already charged with pressure gas, it is necessary to pay the maximum attention in order to avoid accidental release of the gas in the atmosphere.

3 - GENERAL DESCRIPTION

3.1 Unit description

The precision air conditioning units with direct expansion coil of the ED series have been designed for being used in technology centres, computer processing centres, telecom applications and whenever special thermic and humidity conditions are required.

The machines have been conceived for operating with ecological gas R407C (K version), R134A (Ka version), R410A (Kc version) and with refrigerant R22 (without any indication of the kind of gas).

The machines are suitable only for internal installation.

All units are electrically tested at the factory.

The units are supplied with nitrogen pressure cooling circuit for the split version ED.A, while they are supplied with refrigerant charge for the version ED.P; both have anti-freezing oil in the compressor.

The available versions are:

ED...A SF	Free-cooling indoor unit to be connected to a remote condenser;
ED...P SF	Free-cooling monobloc unit with air condenser on board;

The machines are available in different configurations according to the air intake and discharge:

U:	Air intake from the back and upflow air discharge;
D:	Air intake from the back and downflow air discharge.
E:	Air intake from the back and downflow horizontal displacement air diffusion;

The different unit models of the ED Millennium series are marked with initials, whose interpreting key is shown in the scheme on page 5.

Interpreting key for the initials used to mark the air conditioning units of the ED series

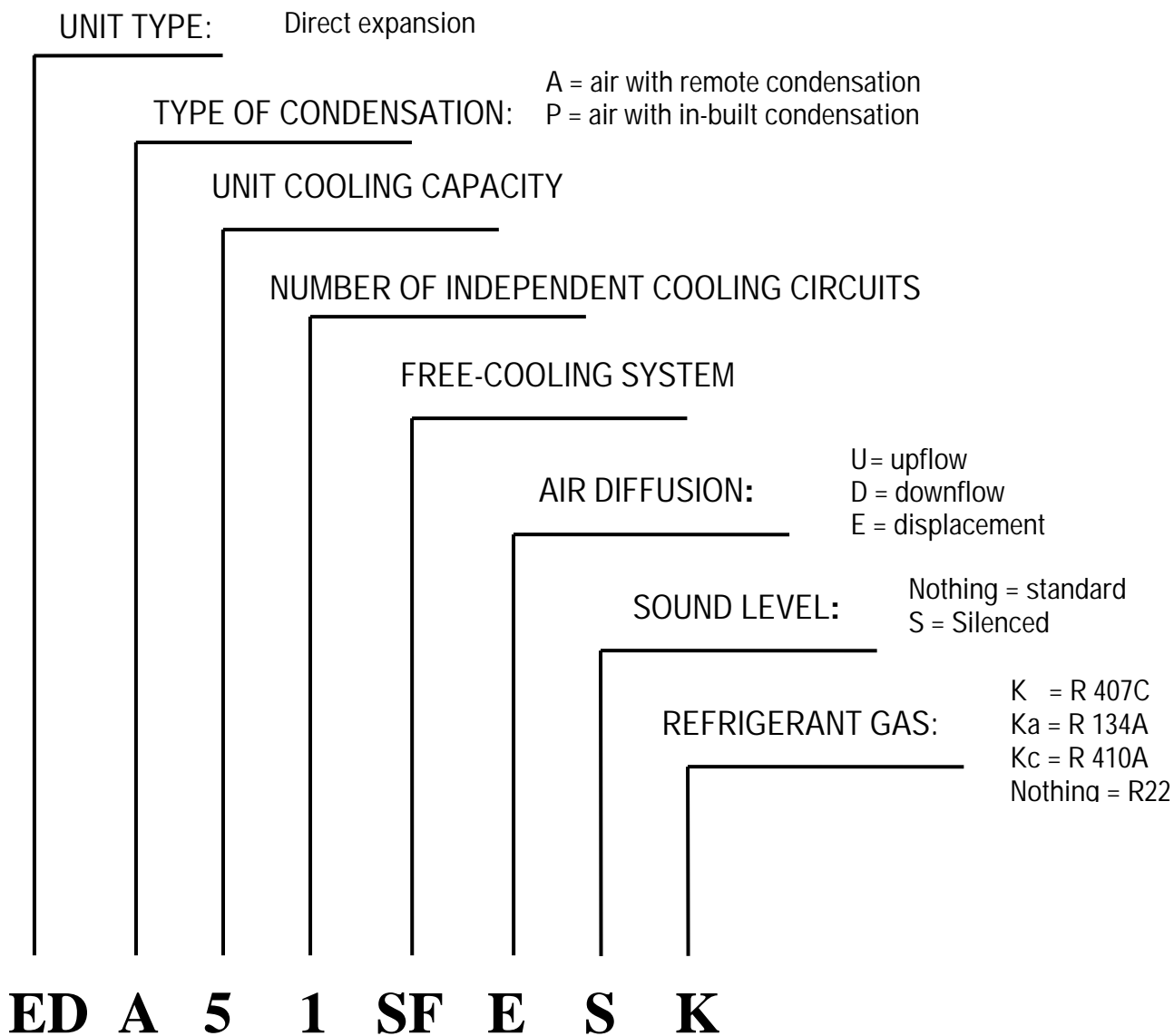

As shown in the scheme in the previous page, the air conditioning units are classified according to the transfer path of the air inside the conditioning machine before being discharged into the working room at the desired temperature. The following pictures show the four possible different configurations, according to the air distribution system.

Version ED.P SF E K

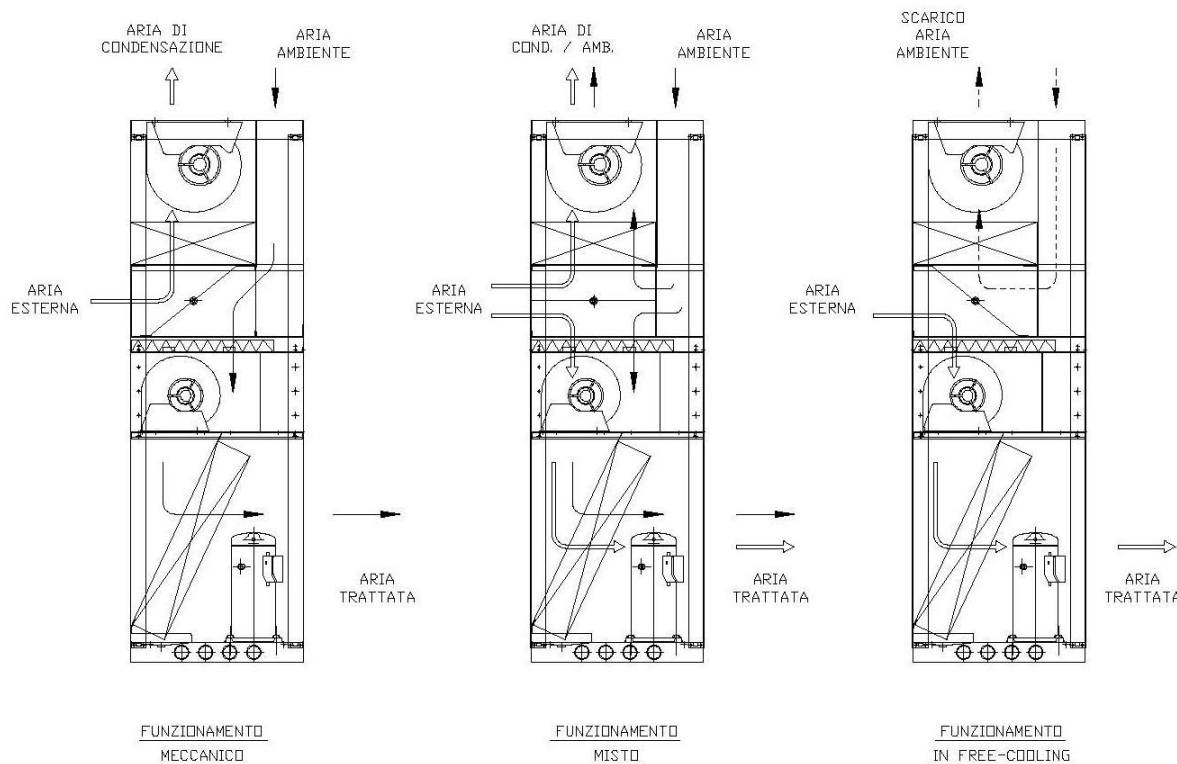

Version ED.P SF D K

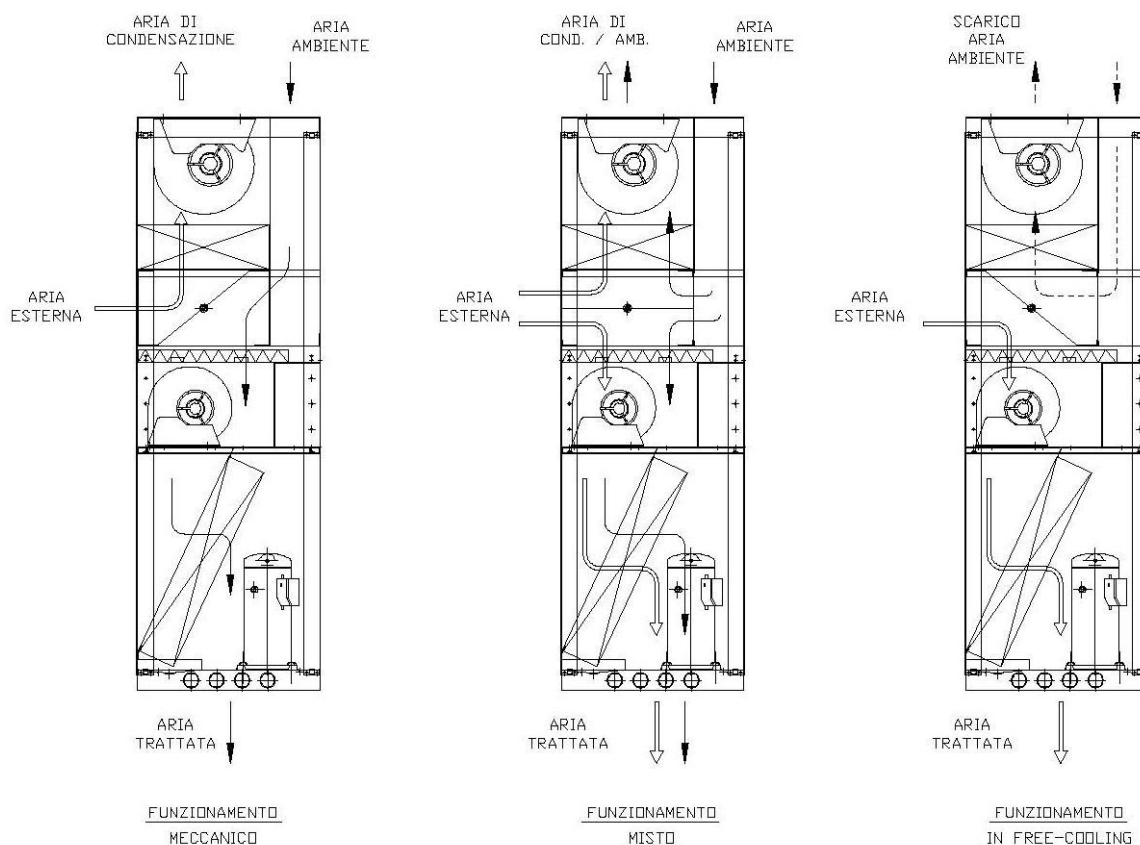

Version ED.P SF D K

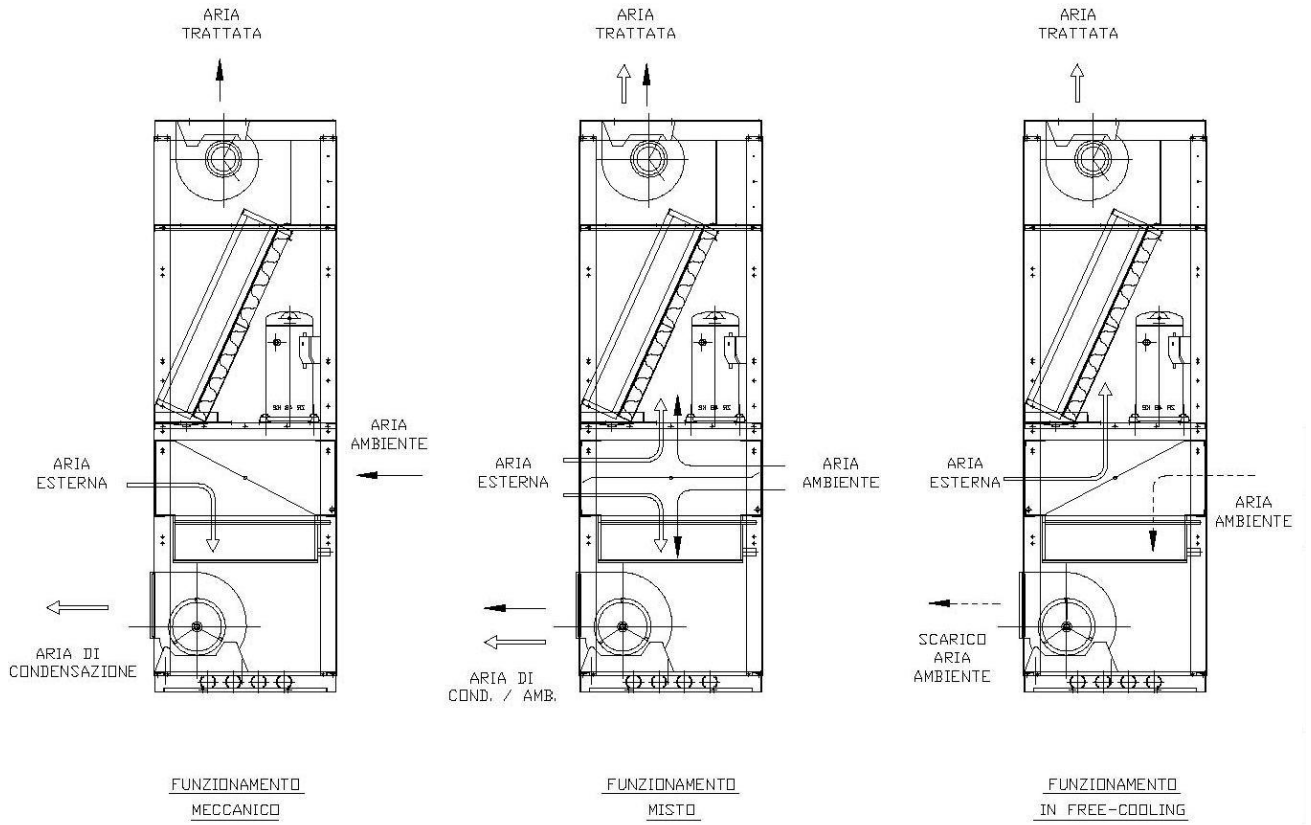

Version ED.A SF E K

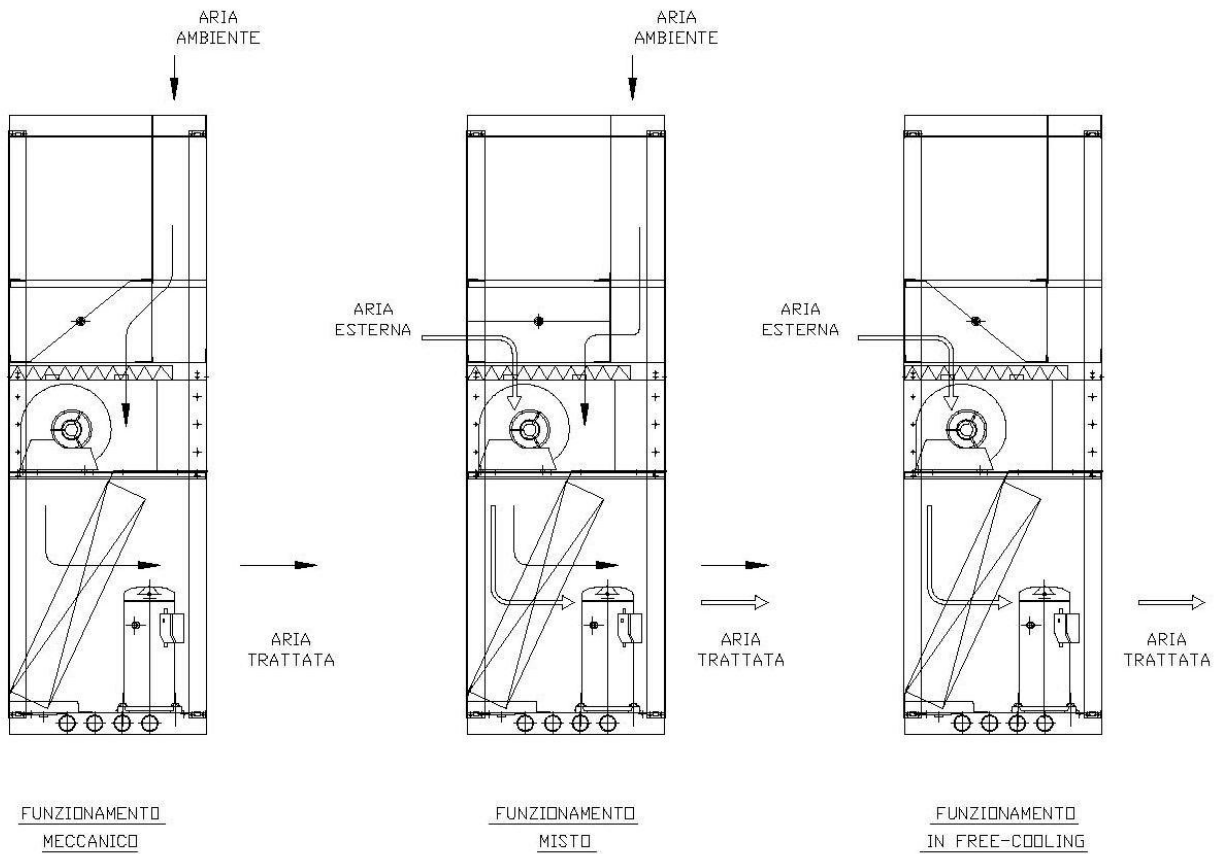

Version ED.A SF U K

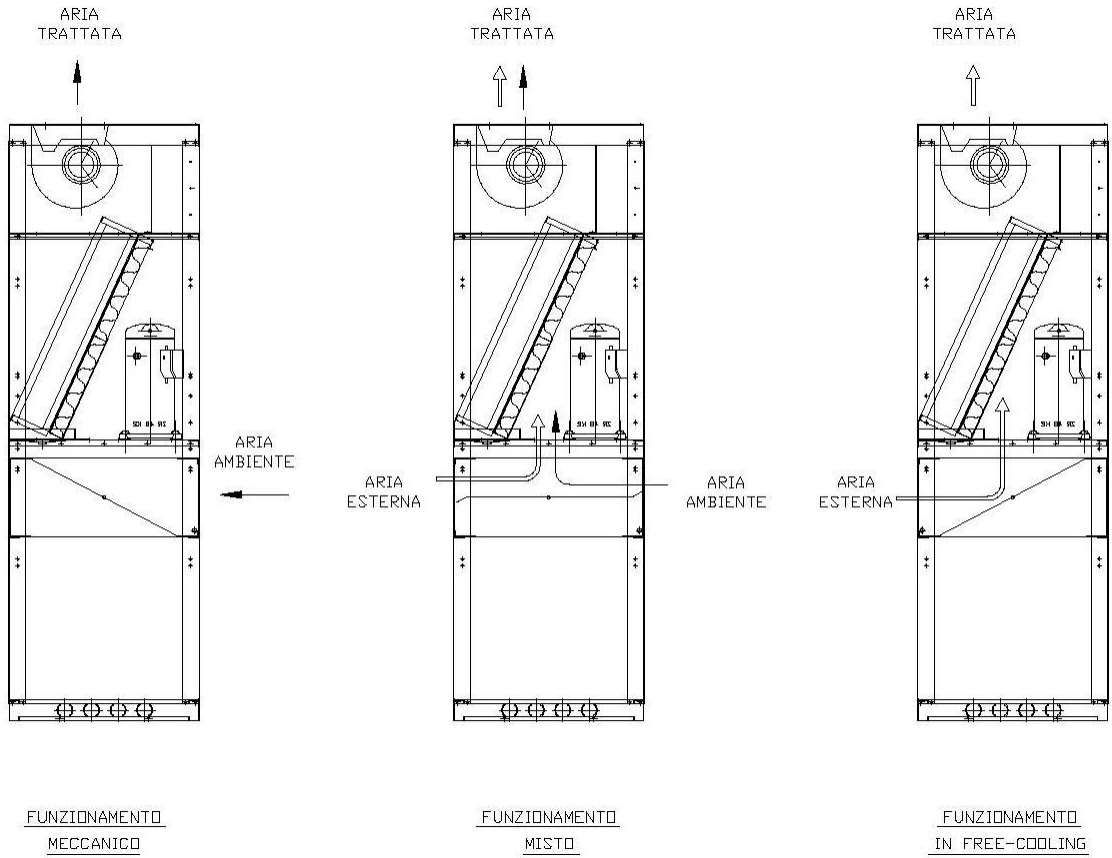

Version ED.A SF D K

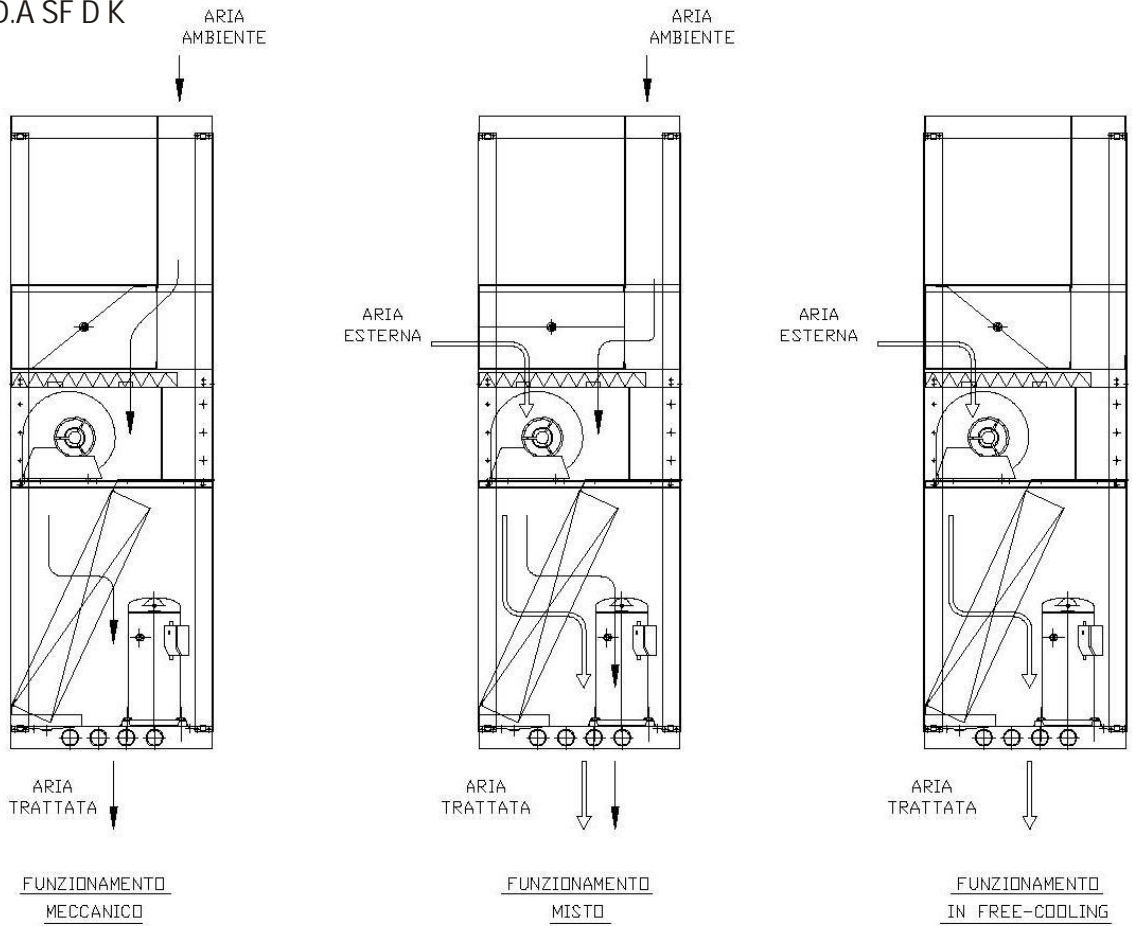

3.2 Main components

The units of ED series are made of the following main components:

- Ø The housing is made of galvanized steel sections covered with plastic-coated steel plate panels. The panels are provided with internal polyurethane plate covers to reduce noise..
- Ø The units are equipped with high efficiency scroll compressors, installed on rubber vibration dampers with thermal protection.
- Ø Centrifugal fans directly coupled with low fan speed regulation
- Ø Direct expansion cooling coil with copper pipes and aluminium fins.
- Ø Stainless steel drain pan.
- Ø Regenerable air filters with efficiency grade F4.
- Ø Cooling circuit composed of all required components for a correct and reliable unit operation, as described in par. 3.2.1.
- Ø The electric board in compliance with CE regulations and provided with main disconnecting switch; thermal and amperometric protections, contactors, auxiliary low voltage circuit, terminal board and control by microprocessor.
- Ø Damper for free-cooling operation

Key:

- 1) Electric board
- 2) Compressor
- 3) Condenser***
- 4) Evaporator
- 5) Free-cooling Damper
- 6) Discharge fan
- 7) Condensing fan ***
- 8) Air filters

*** In the ED.A version points 3 and 7 are replaced by the remote condenser

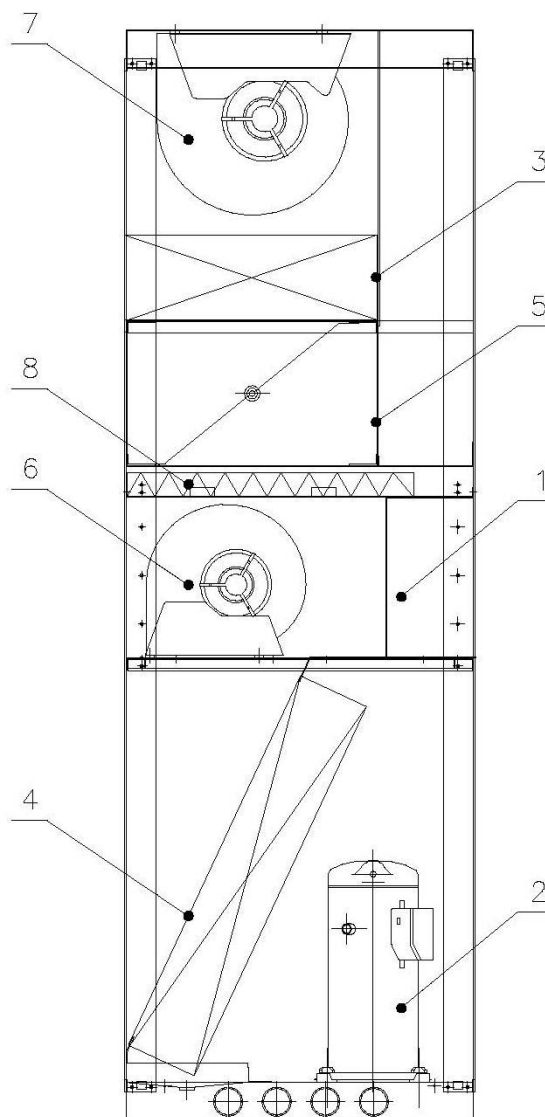

3.2.1 Cooling circuits

Air conditioning unit with inbuilt condenser and Free-cooling system serie ED.P SF

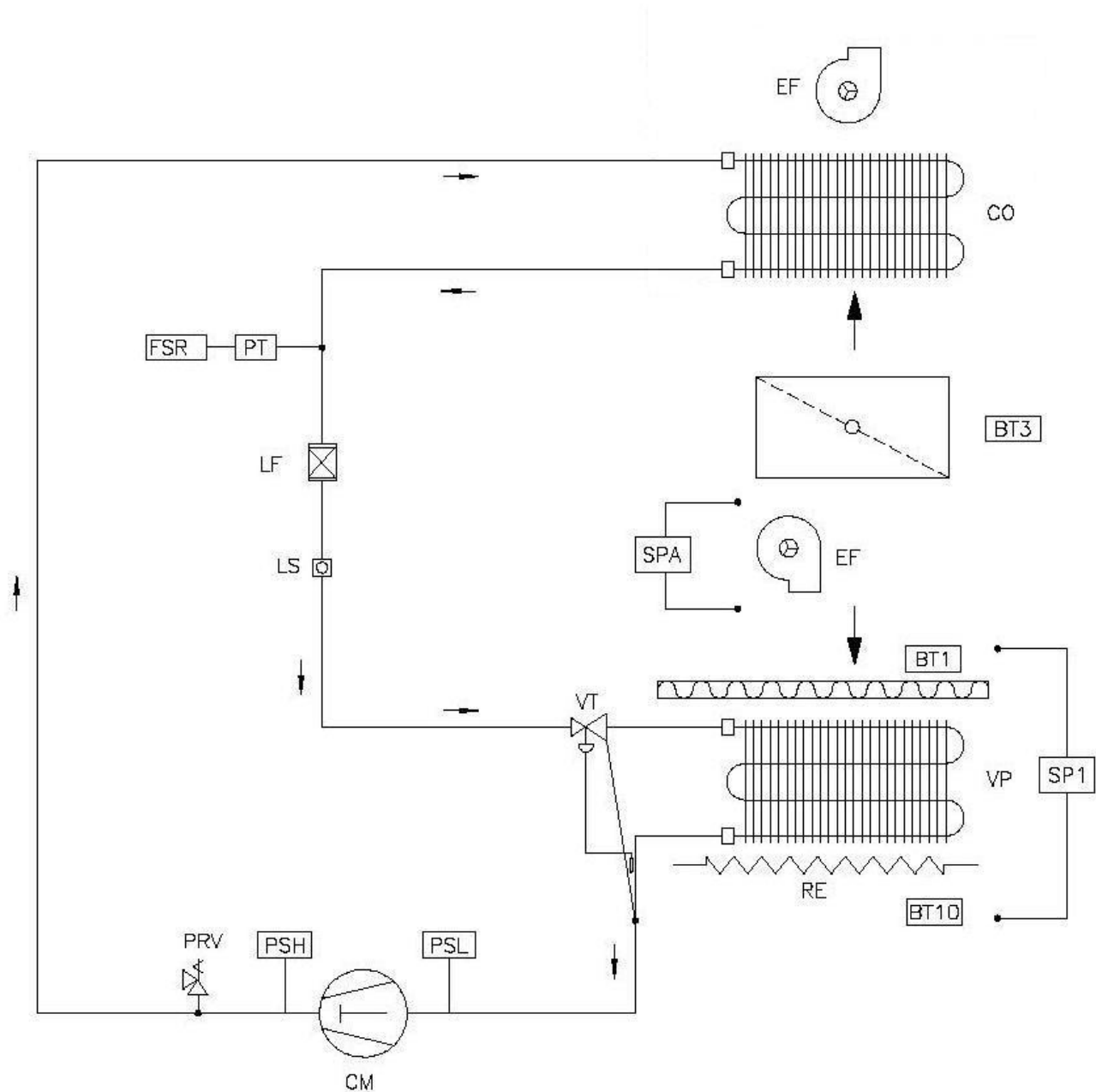

Air conditioning unit with inbuilt Free-cooling system and remote condenser serie ED. A SF

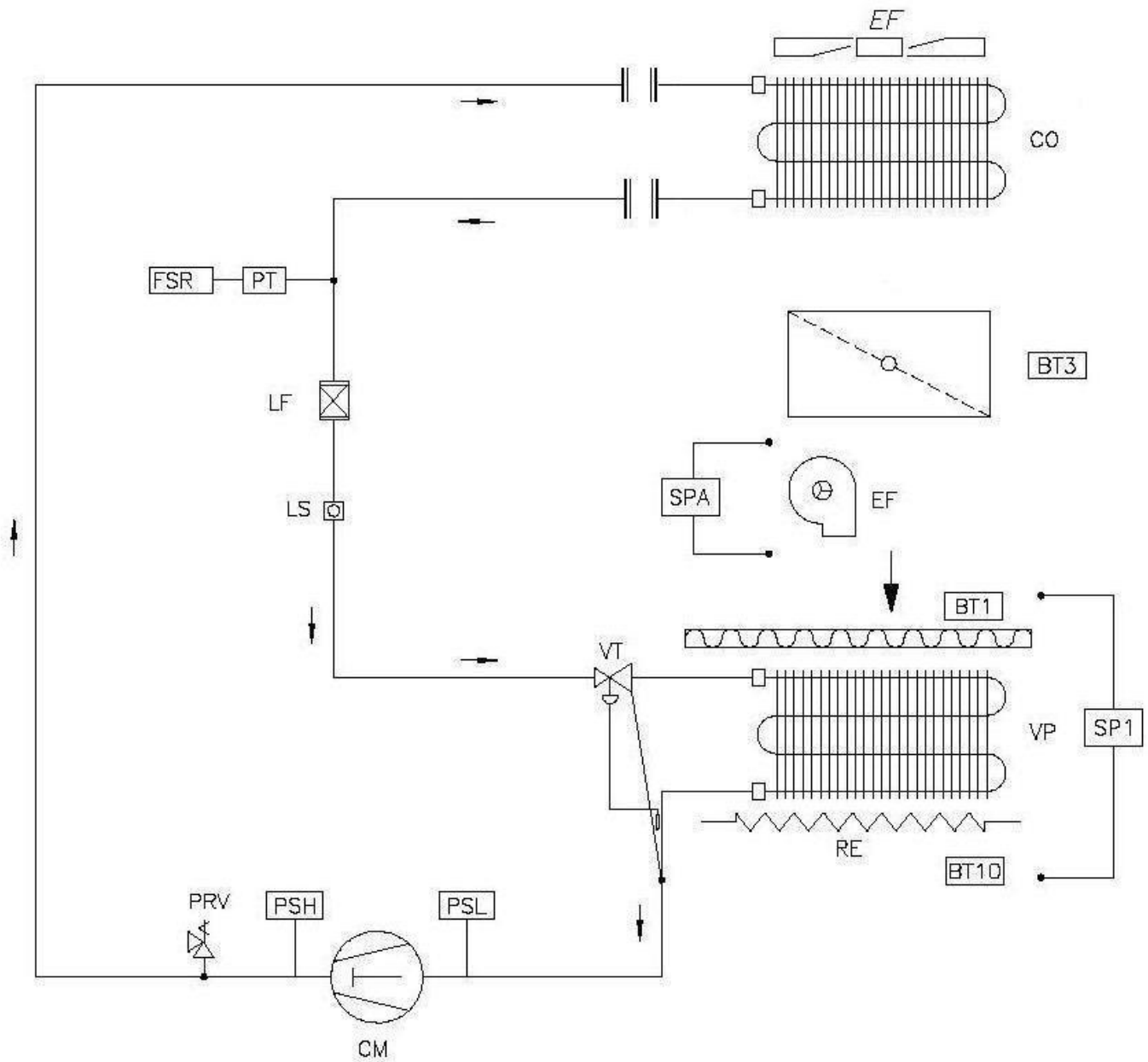

Cooling circuits key

AC	AIR HEAT EXCHANGER	OT	OIL RESERVE	TWV	3-WAY VALVE
AD	AIR DISCHARGE VALVE	PDIO	OIL GAUGE	VE	EXPANSION VESSEL
AV	VIBRATION DAMPER	PDSO	OIL LEVEL PRESSOSTATIC VALVE	VP	EVAPORATOR
BT1	REGULATING PROBE	PDSW	DIFFERENTIAL WATER SWITCH	VT	THERMOSTATIC EXPANSION VALVE
BT3	FREE-COOLING ANTI-FREEZE PROBE	PIH	HIGH PRESSURE GAUGE	WC	WATER COIL
BT 10	ANTI-FREEZE TEMPERATURE PROBE	PIL	LOW PRESSURE GAUGE	WD	WATER CHARGE AND DISCHARGE VALVE
CM	COMPRESSOR	PIW	WATER VALVE	WE	WATER EXCHANGER
CO	CONDENSER	PRV	OVERPRESSURE DISCHARGE DEVICE	WF	WATER FILTER
CT	CONDUCTIVITY PROBE	PRW	SAFETY WATER FLOW SWITCH	WP	WATER PUMP
EF	FAN	PSH	HIGH PRESSURE SWITCH	WT	WATER BUFFER TANK
EHA	ANTIFREEZE HEATER	PSL	LOW PRESSURE SWITCH	BG	HOT GAS COIL
EHC	CRANK-CASE HEATER	PT	PRESSURE TRANSDUCER	YVCA	HUMIDIFIER FILL VALVE
EV	SOLENOID VALVE	RE	ELECTRIC HEATER	YVSA	HUMIDIFIER DRAIN VALVE
FSR	FAN SPEED REGULATOR	RV	MODULATING VALVE	VE	EXPANSION VESSEL
FWV	4-WAY VALVE	SA	LIQUID SEPARATOR	VP	EVAPORATOR
H	HUMIDIFIER	SFF	FREON-FREON HEAT EXCHANGER		
HR	HEAT RECOVERY	SFO	FREON-OIL HEAT EXCHANGER		
HT	HUMIDITY PROBE	SL	NOISE LEVEL REDUCER		
LF	DEHYDRATING FILTER	SO	OIL SEPARATOR		
LS	SIGHT GLASS	SPA	FLOW SWITCH		
LT	LIQUID RECEIVER	SP1	CLOGGED FILTER SWITCH		
NR	NON-RETURN VALVE	SV	SHUT-OFF VALVE		
OF	OIL FILTER	TS	SAFETY THERMOSTATIC VALVE		
OLR	OIL LEVEL REGULATOR	TT	TEMPERATURE PROBE		

3.3 Specification

The main technical features of the units are shown in the attachments.

3.4 Dimensional drawings

The unit's dimensions, ducts' size and when foreseen (ED.A versions) pipes' size to complete the cooling circuit are shown in the attached dimensional drawing.

3.5 Accessories

The units can be equipped with a wide range of optional accessories, the main of which are described in the following list:

AA: Flooding probe sensitive to the water present under the floor.

AE: Power supply different from the nominal power

AL: Smoke alarm.

B: The base frame in welded steel tubes is available for every unit model and its height is adjustable between 140 and 580 mm.

CI: Soundproofing covering on compressor (for silenced "S" versions).

CS: Compressor inrush counter

H: Humidifier.

IG: Watch card.

IH: Serial interface RS485.

IM: Seawood packaging

KC: Spare F4 efficiency filters kit.

MF: Phase monitor

RE: Electrical heater with aluminium armoured elements and safety thermostat

RF: Power factor correction system $\cos\phi > 0,9$

RM: Epoxycoating of the coil for sea environment

RR: Coil with copper/copper fins

For remote condenser

BW: Operaton for external low temperatures (up to -40°C).

C2: two-circuit coils

CV: Wired fans

FV: Supports for vertical air flow version

IM: Seawood packaging

RG: Fan speed controller

RM: Coil with fins in marine alloy

RR: Coil with copper fins

4 - INSTALLATION

4.1 Identification tag

The data for the identification of the unit are marked on a permanent tag (Picture 1) attached both on the packing and inside the unit, close to the electrical panel.

EMICON AIR CONDITIONING AND INDUSTRIAL APPLICATION		TEL. +39 0445 41811 FAX +39 0445 41812 Via Oragoni 85-Pal. 110, V	MADE IN EUROPE	CE
MODEL NUMBER	<input type="text"/>	MODEL NUMBER	<input type="text"/>	
NB 0407	SERIAL NUMBER	SERIAL NUMBER	<input type="text"/>	
DRYING METHOD	Y-FH-Hz	VOLTAGE	<input type="text"/>	
REFRIGERANT TYPE	R	REFRIGERANT TYPE	<input type="text"/>	
WEIGHT	Kg	WEIGHT	<input type="text"/>	
HEIGHT	Kg	HEIGHT	<input type="text"/>	
MAXIMUM PRESSURE	LP bar	MAXIMUM PRESSURE	<input type="text"/>	
	HP bar		<input type="text"/>	
CONSTRUCTION	<input type="text"/>	CONSTRUCTION	<input type="text"/>	

Pict. 1



The correct unit identification by means of the serial number is essential for the execution of any operation to carry out on the unit. The serial number must be always advised whenever submitting a request of technical service support.

4.2 Reception and inspection

It is very important to check the packing integrity immediately upon delivery. In case the packing is found damaged, it is necessary to accept the goods "with reservation" and indicate on the consignment note the state of the received goods and let the driver countersign it. Any claim concerning the delivered material must be sent to the manufacturer by fax or by registered letter within 8 days from the receiving date. It is advisable to unpack the unit only when the installation begins and possibly after the unit has been moved to the location where it must be installed.



It is forbidden to stack units, even if they are packed. If the unit is stored after receiving, it must be not exposed to weather agents, even if packed.

4.3 Handling

The handling of the unit must be carried out by expert personnel, equipped with appropriate equipment in relation to the weight and to the dimensions of the machine. During the handling operation, the machine must be always kept upright.



The weight of some models is unbalanced: check the unit stability before starting to handle it.

For any unit handling, please follow the instructions shown in (Picture 2). In case the fork lift is employed, the forks must be spaced out to the maximum allowed by the pallet size. In case the machine is moved by means of a crane, it is important to avoid that cables and belts exert a too high tractive effort on the packing that might damage it.



Angle α must not be greater than 30° .

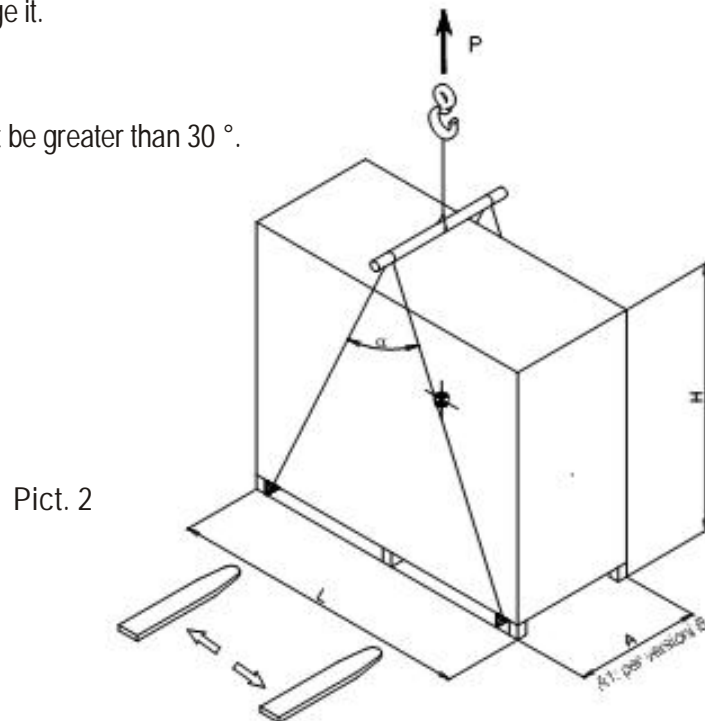

The overall dimensions of the units packaging included are indicated in the packing list sent via @ to arrange loading.

4.4 Arrangements and placing

The installation of the machine is under the responsibility of the installer who must supervise the execution operations. The execution of a correct installation presupposes that a plan has been drawn up by an expert and that is carried out by skilled and trained technicians.

In the following paragraphs there are some tips and information to keep in mind when planning and executing the machine installation.



The unit installation must comply with local existing laws.

Before placing the unit, the following points must be checked:

- Ø Connections for cooling, electrical, hydraulic and condensate drainage circuits must be done;
- Ø Enough room must be left around the unit to allow the routine maintenance, as shown in Picture 3 by the dashed area in front of the machine. It is necessary to keep some free room on the right and/or left side of the unit if connections are on the unit sides. If possible, also leave the necessary free lateral room for special maintenance, such as compressor, heat exchanger and fans replacement;
- Ø The floor where the machine is positioned can bear the total weight of the unit under normal operation

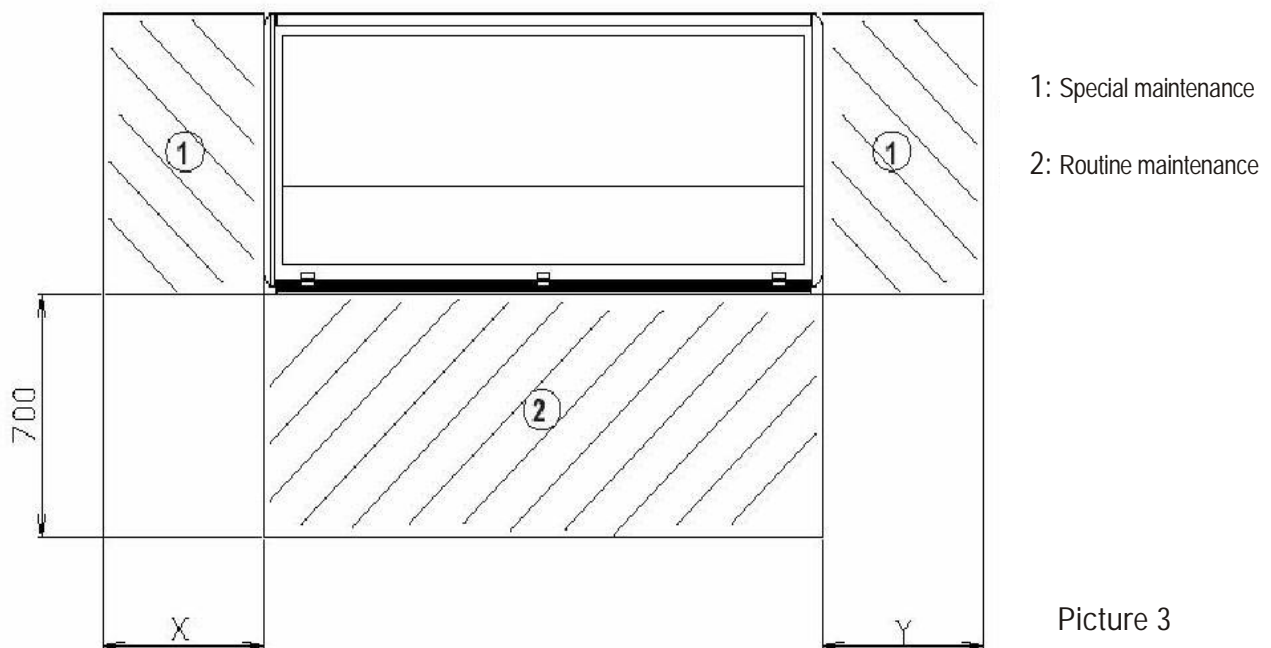

$X = 500 \text{ mm}$

$Y = 500 \text{ mm}$

Before starting to handle the unit to position it, it is necessary to identify the best way to arrive to the place, taking into consideration the unit overall dimensions and weight, the available lifting equipment and any optional accessory dimensions.

All units described in this manual do not need any special foundation, since they can be simply laid down on the chosen surface or arranged on a base frame (option) just placing a rubber gasket of about 5 mm thickness underneath.

Make sure that the aeraulic features of the unit, as described in the attached data sheets, match those required for the undertaken project.

In case of units provided with downflow air discharge, it is necessary to take into account the height of the floating floor because it can greatly influence the unit performance.

In order to avoid high noise level and / or unacceptable reductions of airflow, the height of the floating floor should be never inferior than the unit width.

Make sure that the value of the pressure drop of the air distribution system is not higher than the unit available pressure in its standard configuration. In case of special requirement, higher levels of available pressure are available as an optional on ED.A versions.

Make sure that the number and the characteristics of the air suction and distribution grids are suitable for the unit airflow capacity.

For the installation of any spare accessory, strictly follow the instructions attached to each of them.

4.5 Cooling connections (ED. A)

These units are supplied with nitrogen charge (20 bar). Discharge pressure carefully only before carrying out the cooling connections.

Since the machines are conceived to work with air cooling system, copper pipes must be employed for the connections to their ventilated condenser units which are installed outdoor.

The piping scheme is shown in Picture 4 (ED.A)



Even if refrigerant is not classified as a toxic substance, pay the maximum attention during the refrigerant charge operation and strictly follow the security requirements in compliance with law by decree 81/08 ; in particular, the appropriate and necessary equipment must be worn to avoid contact, inhalation and ingestion.

If any of the above mentioned cases occurs, it is advisable to consult the security specifications for the operations of first aid and emergencies concerning the employed refrigerant.

In case it is necessary to go to the doctor, it is advisable to bring these refrigerant security specifications with you.

Pict. 4: Piping diagram ED.A

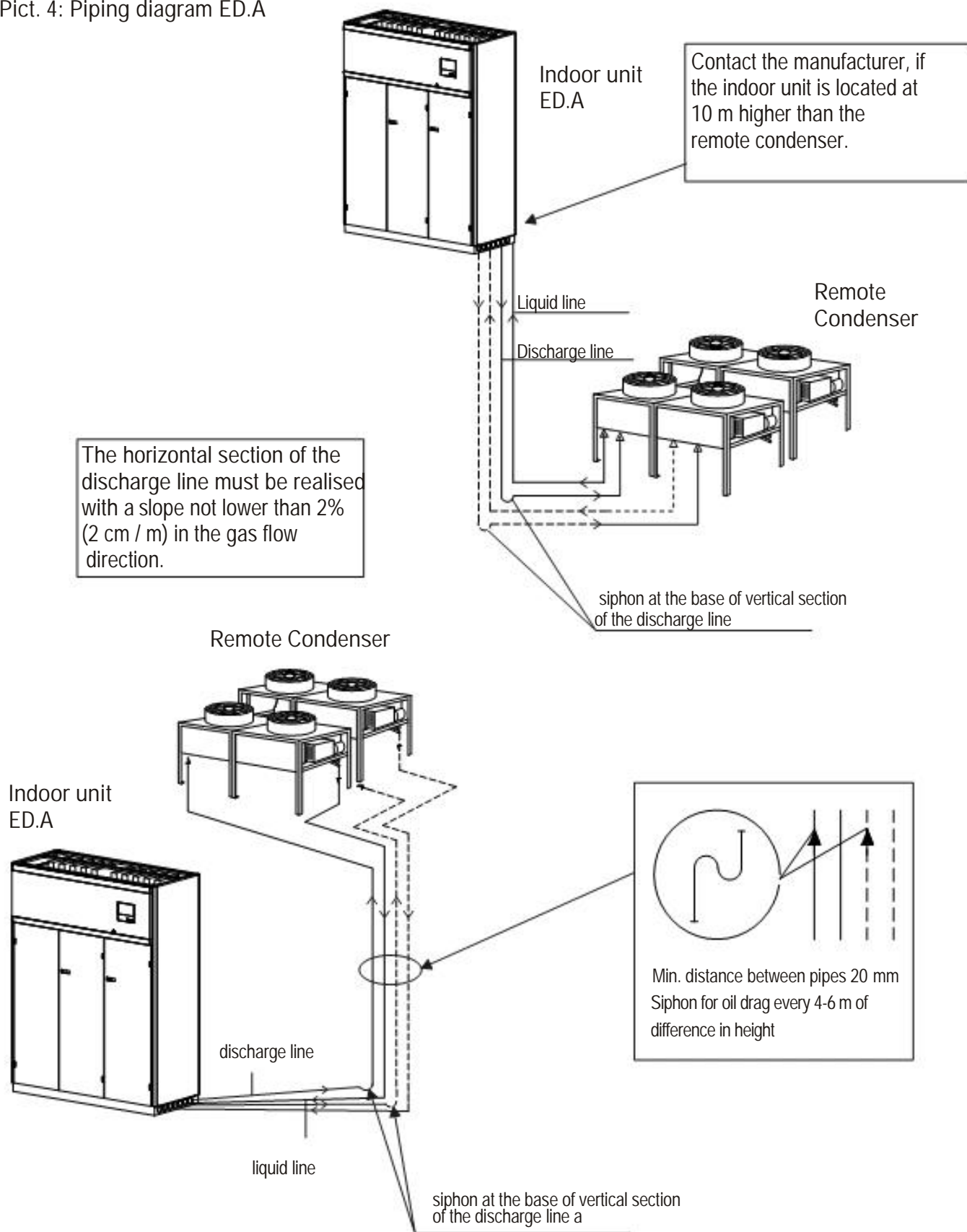

The pipe installation must be performed by a skilled refrigeration technician.

The piping path must be as shortest as possible in order to reduce the quantity of refrigerant gas and oil circulating and to reduce the pressure drop. If copper pipes have to cross electric wires, it is advisable to isolate the tubes in order to avoid the danger of inducted current. Lines must be realised with copper tubes, specifically conceived for cooling systems and they must have an appropriate diameter, as shown in Table 1 (ED.A).

It is here reminded that the total piping length is the result of its geometrical calculation plus the length of valves, bents and fittings present on the line itself. If failing to have more accurate information, you can obtain the total length by multiplying the geometrical length of the line by 1,5 or 2.

Copper pipes must be adequately supported by brackets so as to make them secure and fasten, and at the same time allow thermal expansion of the copper tubes.

If the discharge pipes go through rooms where people normally live, it is advisable to install rubber vibration dampers and a sound attenuator as nearest as possible to the compressor.

The piping insulation, except for special requirements, can be applied on the following parts only:

Ø Discharge pipes (ED.A), where pipes are lapped by the unit air discharge (in the suspended floor);

Ø where pipes can be accessible to unauthorized people so that any damage or skin burn can be avoided.

During the piping installation, the refrigerant tubes must be sealed to prevent humidity and dirt go inside. The piping arrangement must consider easy access for operations like bracket insertion, tube welding and inspection.

Once pipes are placed, before carrying out the connections to the unit, the system must be leak tested by means of pressurized nitrogen. It is recommended to mark the pressure test value on a pressure gauge.



Do not exceed 20 bar when pressing with nitrogen.

The nitrogen also enables the circuit to dry up. If the circuit pressure drops, this means that the circuit is not sealed off. It is, then, necessary to let in a small quantity of refrigerant so that it is possible to locate any leak by means of appropriate detectors. If a leak is detected, after the repair, a new leak test must be carried out again.

Finally, the vacuum and the charge of the system can be executed following the instructions as described in par. 4.9

Pict. 4

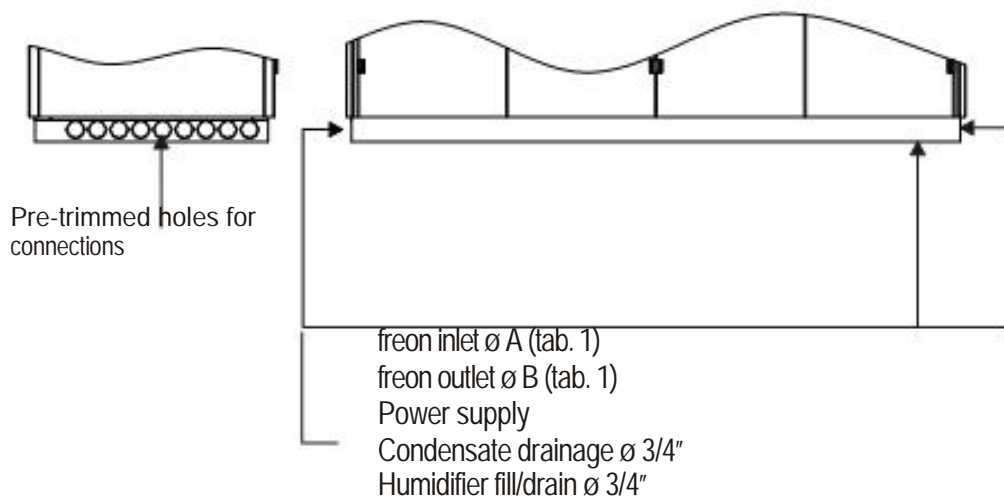

Table 1

ED. A		Leq						Fig. 9					
		10 m		20 m		40 m		ØA	ØB				
		M	L	M	L	M	L						
61		12											
81	172	16	10	16	10	16	10	10	12				
91	192					18				12	18	12	
101	202										22	12	22
121	232			18	12	22	16						
141	272									22			16
151	302			28	16	28	16				28	16	
171	342-362	22	18					35	22	22			
201													35
221	412-442	22	18			35	22						
241	452-482							28	18	35	22		
251	492-532	22	22			35	22						22
291	542-572			22	22			35	22				
301	602									28	18	35	
321	622			22	22	35	22						
341	682							28	18	35	22		
351				22	22	35	22					22	
361	762	22	22					35	22				
431	842									28	18		35
451	892	22	22			35	22						
471	1002							28	18	35	22		
521	1102	22	22			35	22					22	
531				22	22			35	22				
581										28	18		35
601				22	22	35	22						
651								28	18	35	22		
721				22	22	35	22						
821		22						42		22			

Table key:

- Leq: Length of the piping (m)
 L: Recommended diameter for the liquid piping (mm)
 M: Recommended diameter for the discharge piping (mm)
 ØA: Diameter for freon inlet connection
 ØB: Diameter for freon outlet connection

In case of longer lines than what stated in the above table, please contact the manufacturer.

4.6 Condensate drainage connection

The air conditioning unit is provided with a stainless steel tank collecting the condensate generated during the dehumidification phase. The tank must be connected to the drainage collector by means of a flexible pipe having internal diameter of 27 mm. The pipe shall be placed with a slope not lower than 1,5% (1,5 cm/m) toward the outlet direction.



To guarantee a correct condensate drainage, it is necessary to set up a siphon of at least 20 mm in the flexible pipe before doing the connection to the drainage collector.

4.7 Air Connection (version with inbuilt air condensation)

The proper sizing and carrying out of the air connections are essential to grant the good unit's operation and a suitable sound level in the room.

While sizing the ducts pressure drops, air flow and air speed are to be considered and must be congruent to the unit's features.

Particularly consider that pressure drops exceeding the unit's available pressure lead to a flow reduction and consequently to the unit's stop.

4.7.1 Assembling

During the assembling it is advisable to pay attention to :

- Ø The ducts' weight must not rest on the connecting flanges
- Ø Place AV mounts between ducts and unit
- Ø The connection to the flanges and among the several ducts' sections must assure the air tightness, avoiding air loss on the discharge and air return in the suction which penalize the overall plant efficiency
- Ø Possible external ducts must also be watertight
- Ø Limit the pressure drops optimizing the trial course, the type, the number of curves and branching

4.7.2 Minimum Ducts' dimensions

In order to make the ducts' sizing easier, but to make sure that the air flow is the one required to assure the good unit's operation, the following table (TAB. 2) is supplied to provide the available pressure values and the minimum expected duct's surface .

Table 2

MODEL	AVAILABLE PRESSURE Pa	MINIMUM SURFACE Cm ²
51	65	1830
71	65	
131	70	
161	65	
181	70	2562
191	70	
262	70	4026

4.8 Electric connections

Before carrying out the connection of the unit to the power supply, it is necessary to carefully check the following:

- Ø the power tension and frequency are the same data as stated on the unit identification tag (Picture 1);
- Ø make sure there is no humidity trace inside the electrical panel and on all electric and electronic components. In case humidity is found, detect and eliminate the cause of the infiltration;
- Ø make sure the circuit and the electric components have not been damaged during transportation, handling and positioning. If any damage is detected, proceed with the needed repair.
- Ø The electrical wires must be properly tightened; if necessary, tighten adequately any loose wire.



Only authorized and trained personnel can carry out any intervention on the electrical wiring.



Check the wiring diagram placed inside the key board.



Strictly comply with existing local regulations when performing the electrical connections.

4.8.1 Power supply connection (Pict. 5)

The unit standard power supply tension is 400 V/3f/50Hz; on request, it is also possible to supply units with arrangements for special power supply tension (check the identification tag and the wiring diagram).

The unit is normally powered with a 5-pole cable (3 phases + neutral + earth).

Connect the phases and the neutral to the terminals of the main switch (L1, L2, L3 and, respectively, N) and the earth wire to its corresponding terminal (PE). Use a power supply cable of adequate cross section and of moderate length to avoid voltage drops.



Protect the power supply cable by means of an automatic differential switch of appropriate size and features. The cross section of the power supply cable and the size of the automatic switch can be found on the attached wiring diagram, where it is indicated the main switch size according to different unit models and configurations

4.8.2 User's terminal board connection

A user terminal board (Picture 6) is available with free contacts designed for:

- Ø generic alarm state (1);
- Ø unit remote ON/OFF (2).



For the exact correspondence of the terminal numbers, check the wiring diagram.

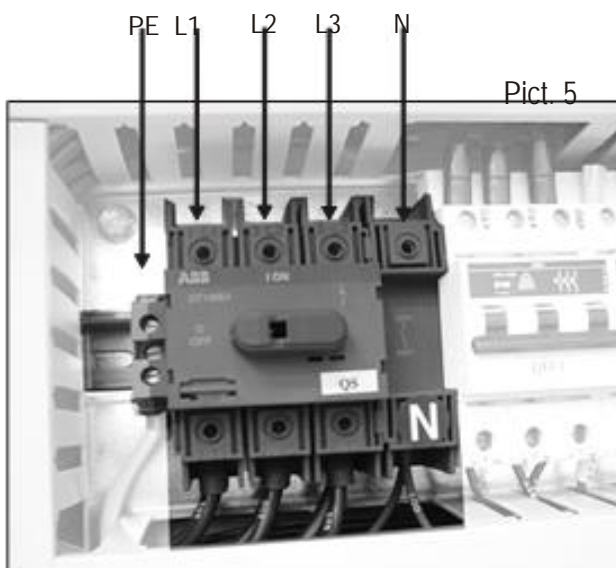

Pict. 5

Pict. 6

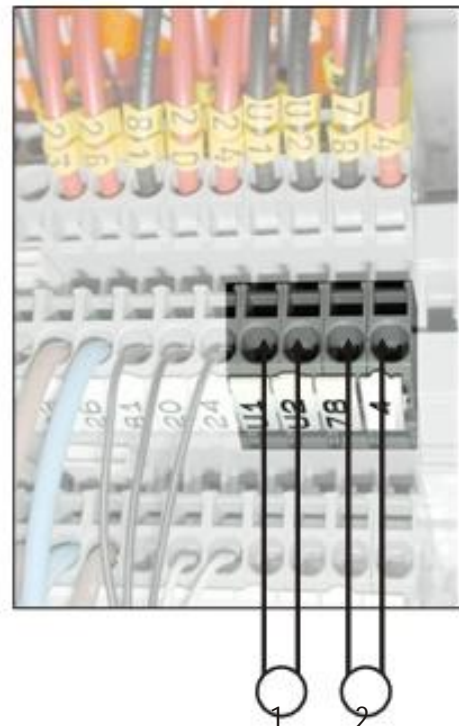

4.8.3 Warning in case of connection to the terminal board when optional "TE" is installed

In case the unit is provided with optional TE (electronic thermostatic valve), pay the maximum attention to the spare battery power supply.

"GB1" (spare battery) is an electronic device which guarantees a temporary power supply to the "Driver" device in case of sudden power supply shortage, thus allowing the immediate shutoff of the thermostatic valve

Before performing any operation, it is advisable to check the charge of the battery as per the instructions;

- Ø power the control
- Ø press the button I/O
- Ø check parameter N4

For further information, check the control manual on chapter 7, section "input-output/driver" and chapter 9. If battery is flat, 48 hours are needed to charge it.

During the check-up operation before the unit startup, it is advisable to disconnect the spare battery to avoid that continuous power and disconnection operations might damage it.

- open the duct above the component GB1 (driver battery EVV) and disconnect the power supply cables (see the picture)



Once the check-up test is completed, it is reminded to re-connect the battery to bring the air conditioning unit in a safety status

4.8.4 Condenser connections (ED. A)

The condensers must be connected to the appropriate wire terminals in the indoor unit by means of an electric cable having an adequate diameter and suitable features related to the capacity and the environment.

4.9 Vacuum and charge execution of the system (ED.A,)

4.9.1 General warnings

For a correct and reliable operation of the system, once the connection lines between the indoor and the outdoor units are carried out, it is extremely important to clear the circuit of any air, humidity, non-condensable gas and, in general, of any polluting substance presence before executing the refrigerant charge. The presence of solid particles like metal dust, welding debris and dirt of small dimensions that cannot be detected by the mechanical filters can cause serious damages to the surfaces in movement and involve a reduction in efficiency and of compressor life



Do not perform any holes in the cooling circuit, the complete rescue of metal particles produced would be then prevented.

If excessive humidity persists inside the cooling circuit, negative consequences can arise. Humidity can freeze inside the thermostatic valve and can even clog it up, causing the unit stop because of the low-pressure alarm. A significant amount of humidity can saturate the filter drier in a very short time and it will be necessary to replace it (with consequent operating interruption of the system). Humidity chemically interacts with the refrigerants and especially with polyester lubricant oils (normally employed with refrigerant type R407C, R134a, R404A, etc.). This interaction creates acid substances that, if present in fair amount, can damage the compressor electric motor insulation provoking motor burns and rusted copper pipes that can generate solid impurity.



Reduce as least as possible the exposure of the circuit and its part to the atmosphere, especially if compressors are charged with polyester oil.

If non-condensable gases are not eliminated accurately from the circuit, they can gather inside the condenser and the liquid receiver. If gases are in the condenser, they can cause a reduction of the useful thermal exchange surface, meaning a condensing temperature increase and, consequently, a reduction of the energy efficiency and of the system reliability. In worst cases, the unit can be stopped by the activation of the high-pressure switch. Big amounts of non-condensable gases gathered in the liquid receiver can cause the malfunctioning of the thermostatic valve, in case a mixture of refrigerant and non-condensable vapor replaces liquid refrigerant. If this happen, there will be a strong reduction of the evaporating temperature up to the activation of the low-pressure switch, in worst cases, thus involving a reduction of the unit cooling capacity and a reduction of the system efficiency and life.

Pict. 7



Pict. 8





4.9.2 Vacuum execution

Once the cooling lines are completed and checked that no leaks are present, the vacuum must be executed as described here below (see Par. 4.5).



The indoor unit is normally leak tested by the manufacturer by cooling circuit pressurization.

 The unit is supplied with nitrogen pressure (20 bar). Therefore, if during the installation it results that the cooling circuit is not pressurized, this means that there is a leak. It is necessary to detect it and repair it before going on with the installation operations.

 Before starting the circuit vacuum operation, make sure all nitrogen contained in the liquid receiver has been discharged.

a) Connect a vacuum pump (a two-stage pump able to keep a pressure of 0,04 mbar - Pict. 7) to the system employing the charge connections present on suction (Picture. 8) and on liquid lines.

 Do not use the compressor for carrying out the vacuum inside the cooling circuit.

 Make sure all valves are open in order to avoid that some circuit parts result cut off.

b) Let the vacuum pump work until the pressure shown on the appropriate vacuum meter (Picture 8) does not go below 10 mbar.

c) Isolate the pump from the circuit by means of the appropriate cut-off valves and wait for 30 min.

d) If pressure goes on increasing during the pump stop period or if it is impossible to reach the desired pressure value, it means there is a leak in the circuit. It is necessary to detect and repair the leak, and after that, a new procedure must be performed again starting from step b).

e) If pressure goes up until it reaches a climax value, it means the circuit contains a big amount of humidity. In this case, it is necessary to let in nitrogen in the circuit (up to about 2 bar) and then repeat steps b), c) and e) for at least twice, then proceed with step f).

f) If pressure stabilizes after a short increase, it means the circuit is leak proof and reasonably dried. Start up again the pump after the shut-off valves are open and let it operate for 2-4 hours according to the circuit size after pressure has returned below 10 mbar.

 Do not operate the compressor nor employ a megahom meter while the circuit is vacuum.

4.11.3 Refrigerant charge execution

Once vacuum is completed, the circuit must be charged with the exact quantity of refrigerant and, if necessary, of anti-freeze oil.

 Avoid any refrigerant gas release in the environment during the charge operations.

 ED.P units are supplied with refrigerant and anti-freeze oil charge included, therefore they must not undergo the following operations, unless some maintenance operations on the cooling circuit are needed

a) Connect a full up refrigerant gas cylinder to the circuit employing the charge connections present on the liquid line.

 Make sure the refrigerant you are going to use for the circuit charge is the same as shown in the unit identification tag. In case of discrepancies, contact the manufacturer.

b) Open the cylinder valve and charge the refrigerant until the circuit pressure reaches the same pressure as in the cylinder (if needed, repeat the operation with additional gas cylinders).

 If the refrigerant is a mixture compounds, make sure to let enter the circuit in a liquid state in order to avoid compounds separation. On this purpose, cylinders are provided with two distinct valves: one for the vapor and one for the liquid.

c) Shut off the cylinder valve, disconnect it from the liquid line and connect it to the suction line (possibly prior to the evaporator)

d) Start up the unit, open the cylinder liquid valve and complete the charge (if needed, use more cylinders) until the sight glass located immediately after the filter drier becomes clear and does not present foam or gas bubbles during the operation in nominal conditions.

In order to facilitate the charge operation, the following tables show, as an indication, the necessary amount of refrigerant to charge the different types of indoor units and the corresponding connecting pipes. For a correct calculation of the refrigerant quantity, it must be also taken into account the volume of the outdoor unit cooling circuit and of any other component installed (such as additional liquid receivers, oil separators, etc.). In case the cooling lines are very long or in case oil separators are installed on the compressors discharge, a fair quantity of anti-freeze oil must be added.



Check if the employed oil is compatible with the one charged in the compressor (check it out in the compressor's identification tag).

In case oil separators are employed, add the lubricant quantity suggested by the manufacturer. If cooling lines are longer than 30 m, charge about 0,2 kg of oil every 10 m of piping (beyond 30 m). In any case, check the correct oil charge by checking the oil level through the compressor sight glass after about 30 minutes of standard operation mode.



An overload oil charge can lead to a system efficiency drop and to compressor breaking.

Table 3

Table 10.c		Refrigerant weight for every 10 m of piping											
D _e (mm)		6	10	12	16	18	22	28	35	42	54	64	76
M _{asp} (kg/10)	0,003	0,013	0,020	0,040	0,052	0,079	0,13	0,20	0,30	0,49	0,71	1,0	
M _{man} (kg/10m)	0,011	0,042	0,07	0,13	0,16	0,25	0,42	0,6	1,0	1,6	2,3	3,3	
M _{liq} (kg/10)	0,15	0,55	0,86	1,7	2,2	3,3	5,6	8,4	13	21	30	43	

Table key

D_e = external pipe diameter

M_{asp} = refrigerant weight for the suction line

M_{man} = refrigerant weight for the discharge line

M_{liq} = refrigerant weight for the liquid line

5 - OPERATION

5.1 First startup

Before starting the unit, the following simple operations must be carried out.

5.1.1 Cooling circuit (ED.A, ED.P)

Once all operations are completed as described in par.4.9 'Vacuum and charge execution of the system', the unit is ready for the startup. Make sure the valves are open according to the following instructions:

- Ø Unscrew the stylus protective cap (Pict. 9);
- Ø Rotate the stylus anti-clockwise until the end (Pict. 10);
- Ø Rotate the stylus clockwise for one turn (if the manometer plug 1 is employed);
- Ø Screw well the cap tightening it, so to avoid any gas leakage.

Pict. 9



1

Pict. 10



5.1.2 Startup

Perform all operations as described in par. 4.10 'Electric connections' and then follow the instructions here below:
Portare Turn the main switch to ON position; make sure the unit is OFF from the keyboard.

-  Wait at least for 3 hours before starting the unit to allow the oil sump heater to pre-heat the oil. Start the unit pressing the ON/OFF button on the microprocessor keyboard..



In case of 3-phase motors, check the fans and the compressors rotation direction; if rotation is reversed, two out of the three phases must be inverted in the terminals of the main switch.

Once the unit is started, after a short period needed to the microprocessor for an auto-test, the unit electric fans will start to rotate. At this point, all system components will start working automatically according to the selected and detected thermal and humidity parameters.

To stop the air conditioning unit, push the ON/OFF button on the microprocessor keyboard.



If the unit should not work for more than 24 hours, turn the main switch to OFF position.

5.1.3 Setup

The setup must be performed when the unit is operating in conditions as close as possible to the nominal ones.

Make sure:

- Ø The thermal load is adequate;
- Ø Doors and windows are shut;
- Ø Surrounding spaces are clean.

Check the suction gas heating and, if needed, adjust the thermostatic valve setting as described here below. When the unit is working in nominal conditions, connect a manometer on the low pressure side. Check the gas temperature on the compressor intake (Picture 12) by means of a thermometer (Picture 11). The overheating intake value is the difference between the detected temperature and the saturation temperature (dew value for mixture) corresponding to the pressure shown on the manometer. If overheating is over 10°C, the thermostatic valve must be opened, while if it is below 5 °C, the valve must be shut off (Picture 13 cap removal and Picture 14 opening adjustment).

Valve adjusting operations must be always carried out with caution, turning the adjusting screw only half turn each time; wait for few minutes before every new adjustment in order to allow the unit to reach steady conditions.

Pict. 11



Pict. 13



Pict. 12 example

Gas: R407 C
 Intake temp.: 15°C
 Intake pressure: 5,5 bar
 at 10°C
 Overheating:
 15 - 10 = 5°C

Pict. 14



The thermostatic valve adjustment is a very delicate operation, therefore it must be carried out by a skilled technician.

5.1.4 Microprocessor setting

Make sure the desired thermal and humidity parameters are set on the microprocessor.

If the preset parameters need to be changed, proceed as described in the microprocessor manual (see attachment).



Standard units are designed to work with room temperature between 22 and 27 °C (50% relative humidity); working at lower temperatures can generate frost on the evaporator.

5.1.5. Steam production setting (unit with humidifier)

Steam production must not exceed 60 - 70% of humidifier maximum capacity in order to guarantee a long operating life of the unit.

To set and modify the operating parameters, check the humidifier manual (here attached).

Table 4: Safety devices setup

Device	Bar Intervention	Bar Reset
High pressure switch	27,5	22
High pressure safety valve	29	
Low pressure switch	2,3	3,5

5.2 Fault alarm and display system

The troubleshooting is realised by the microprocessor, which activates an alarm and shows on its display the type of fault occurred (see also the attached microprocessor manual).

Since the alarm state is very often generated by an unfitted electric contact, in case of fault make sure all wiring connections are plugged in the corresponding terminals.

In case of fault, consult the attached microprocessor manual to check the parameters setting has been done properly.

5.3 Troubleshooting

TROUBLE	POSSIBLE CAUSE	CHECK / CORRECTIVE ACTION
1) The unit does not work	A) The electric panel is not powered	Check presence of electric tension; make sure the main switch is closed.
	B) The auxiliary circuit is not powered	Check fuses FUT and FUA
2) The unit does not start	A) The microprocessor does not start the unit	Check the electric connections to the microprocessor
	B) The external impulse to the microprocessor fails	Check the remote ON/OFF contact is closed
3) Room temperature too high (high temperature alarm signal)	A) The unit does not work	See troubles 1 and 2
	B) The control system setting is not correct	Check the setting of the control system
	C) The air flow capacity is too low	See trouble 6
	D) The compressor does not work	See trouble 13
	E) The compressor output is not sufficient	1) See trouble 9 2) See trouble 12
	F) The control system does not work	Consult the attached Microprocessor manual
	G) Thermal load higher than estimated	Check the room thermal load value
4) Room temperature too low (low temperature alarm signal)	A) The control system setting is not correct	Check the setting of the control system
	B) The electric heaters do not work (if installed)	See trouble 15
	C) The control system does not work	Consult the attached Microprocessor manual
	D) Thermal loss higher than estimated	Check the thermal loss value
5) Room humidity too high (if the humidity control is installed) (high room humidity alarm)	A) The control system setting is not correct	Check the setting of the control system
	B) Latent load higher than estimated	Check the room latent load value
	C) The compressor does not work when in dehumidification phase	See trouble 13
	D) The control system does not work	See the attached Microprocessor manual
6) Low or no air flow (flow or fans alarm)	A) Fans are not powered	Check the fans electric circuit
	B) Clogged filter (filter alarm, if installed)	Clean or replace the filter
	C) Obstruction in the air duct or excess of pressure drop in the air ducts	Check the total pressure drop and compare it with the unit available pressure
	D) Fan heat protection system is activated	Check fan winding resistance; after reset, check tension and electric absorption
7) High pressure switch is activated	A) The control system of the condensation pressure is not working properly (if installed)	Make sure the control system of condensation is set and it works
	B) One or more condensing fans are out of order (ED.A, ED.M units)	Check that the internal heat protection of the out of order fans does work: replace the defective fans
	C) The high pressure switch is not properly set	Replace the high pressure switch
	D) Output pressure too high	See trouble 9
	E) The condensation water capacity is not sufficient (ED.W unit)	1) Check all valves are positioned correctly; 2) Make sure there is no air in the circuit
8) Low pressure switch is activated	A) Low pressure switch is not set	Replace the low pressure switch
	B) Suction pressure too low	See trouble 12

TROUBLE	POSSIBLE CAUSE	CHECK / CORRECTIVE ACTION
9) Compressor high pressure output	A) Air to the condenser too hot	Check the presence of any condensation air re-cycle
	B) Insufficient condensation air flow	Make sure there is no obstruction to the air flow in the finned exchanger coil (see par. Arrangements and placing)
	C) Suction pressure too high	See trouble 11
	D) Clogged fins of the condenser coil	Clean the exchanger coil removing the clogging material (leaves, paper, seeds, etc.)
	E) Circuit charged with too much refrigerant: condenser partially flooded	Under-cooling of the refrigerant too high: remove some refrigerant from the circuit
	F) Non condensable air or gas in the circuit	The flow sight glass presents gas bubbles. The compressor discharge temperature is high; the cooling circuit must be discharged and recharged after the vacuum execution
	G) Too hot water to the plate condenser	Check the capacity of the condensation water cooling system
	H) Insufficient condensation water flow capacity	Check the system pressure drop and compare it with the pump available pressure
	I) Plate condenser encrusted	Wash the exchanger with specific products
10) Compressor low pressure output	A) The control system of the condensation pressure is not working properly	Check setting and working of the condensation control system
	B) Suction pressure too low	See trouble 12
11) Compressor suction high pressure	A) Thermal load higher than estimated	Check the room thermal load value
	B) Discharge pressure too high	See trouble 9
	C) Liquid refrigerant return to the compressor intake	Make sure the overheating of the thermostatic valve is correct; check the valve bulb is well placed, fixed and insulated.
12) Compressor suction low pressure (possible frost on the coil battery)	A) Room temperature too low	See trouble 4
	B) The air flow capacity is too low or absent	See trouble 6
	C) Clogged refrigerant filter	Check the refrigerant filter
	D) Defective thermostatic valve or not properly set	Check the overheating of the thermostatic valve is correct: check the thermostatic element is not broken
	E) Insufficient refrigerant charge	Check possible leakage and recharge
	F) Discharge pressure too low	See trouble 10
13) The compressor does not work	A) Automatic switch activated	Reset the automatic switch; check the cause of the short circuit
	B) Compressor internal heat protection activated	Check the compressor winding resistance; after reset, check tension and electric absorption; check the working parameters are in the normal range of values
	C) Contactor does not work	Check the contacts and the contactor coil
14) The compressor is noisy	A) Liquid return to the compressor	Check working and overheating of the expansion valve
	B) The compressor is damaged	Replace the compressor
15) The electric heater does not work (if installed)	A) Safety thermostat activated	1) The air flow capacity is too low: see trouble 6 2) Check if safety thermostat works properly and replace it if needed
	B) Fuses activated	Replace the damaged fuses
	C) Contactor does not work	Check the contacts and the contactor coil
16) Probe alarm	The probe corresponding to the alarm code is defective or disconnected	Check the connection of the probe; in case of defect, replace it

5.4 Routine maintenance

	Monthly	Quarterly	Annual
Air filter cleaning	X		
Condensate tank cleaning		X	
Condenser coil cleaning			X
Humidifier cleaning		X	
Check of cooling lines and their insulation		X	
Compressor noise level check	X		
Fans noise level check		X	
Electric connection tightening check		X	
Contactors status check		X	
Check of duct insulation status			X
Check damper and probes for free-cooling		X	
Sight glass check		X	
Electric absorption check		X	
Working pressures check		X	
Unit general conditions check			X
Probe setting check			X
Set parameters check		X	
Refrigerant filter pressure drop check			X
Safety valve check			X
Safety pressure valve check		X	
Electric protection check		X	

6 - DISMANTLING

When the unit has to be dismantled, drain the cooling circuit and collect the refrigerant gas by means of an adequate receiver, in order to protect people and environment.



Never release the gas contained in the cooling circuit in the environment.

When dismantling the unit or when replacing the compressor, carefully collect the oil compressor and deliver it to an authorized company for oil disposal.



Never release the oil compressor in the environment.

USE AND MAINTENANCE MANUAL

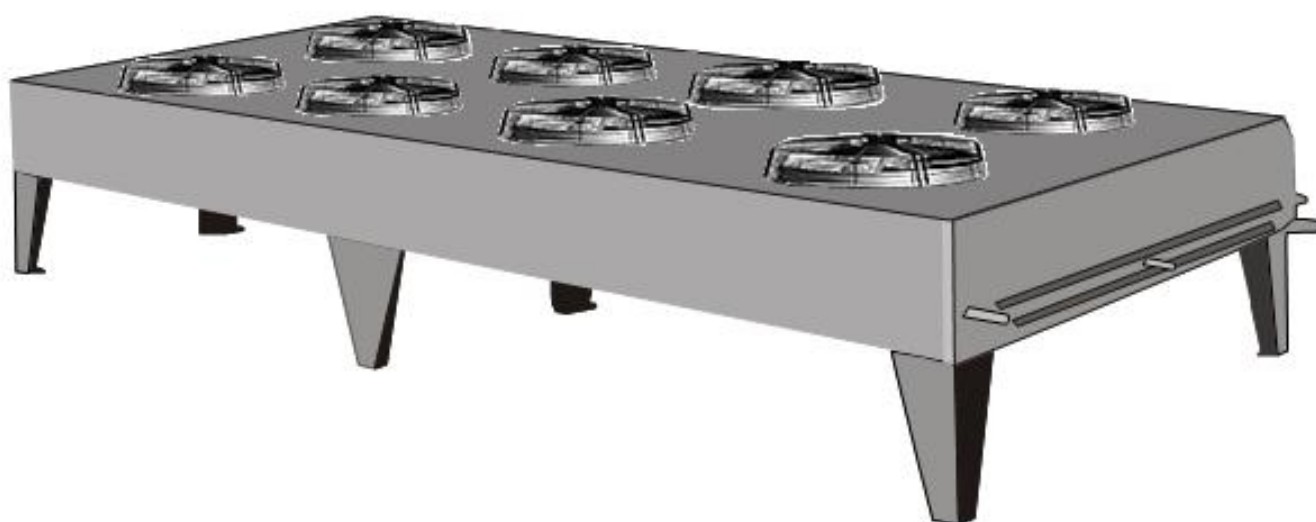

AIR CONDENSERS

With axial fans

CR/CRS/CRU

TABLE OF CONTENTS

1	WARNINGS	Pag. 36
2	TRASPORTATION	Pag. 37
3	CHECKS FOR A CORRECT INSTALLATION	Pag. 37
4	WARNING FOR A CORRECT PLACING	Pag. 38
4.1	Technical Specification	Pag. 38
4.2	Placing	Pag. 38
4.3	Electric connections	Pag. 38
5	INSTALLATION	Pag. 39
6	GENERAL MAINTENANCE	Pag. 40

1 - WARNINGS

Keep this technical manual all along the condenser's life.

Read carefully the manual before the installation and before any operation on the unit.

Use the condenser only for the use it has been designed for: the manufacturer disclaims all responsibility in case of misuse.

The interpreting key for the condenser initials is described here below::

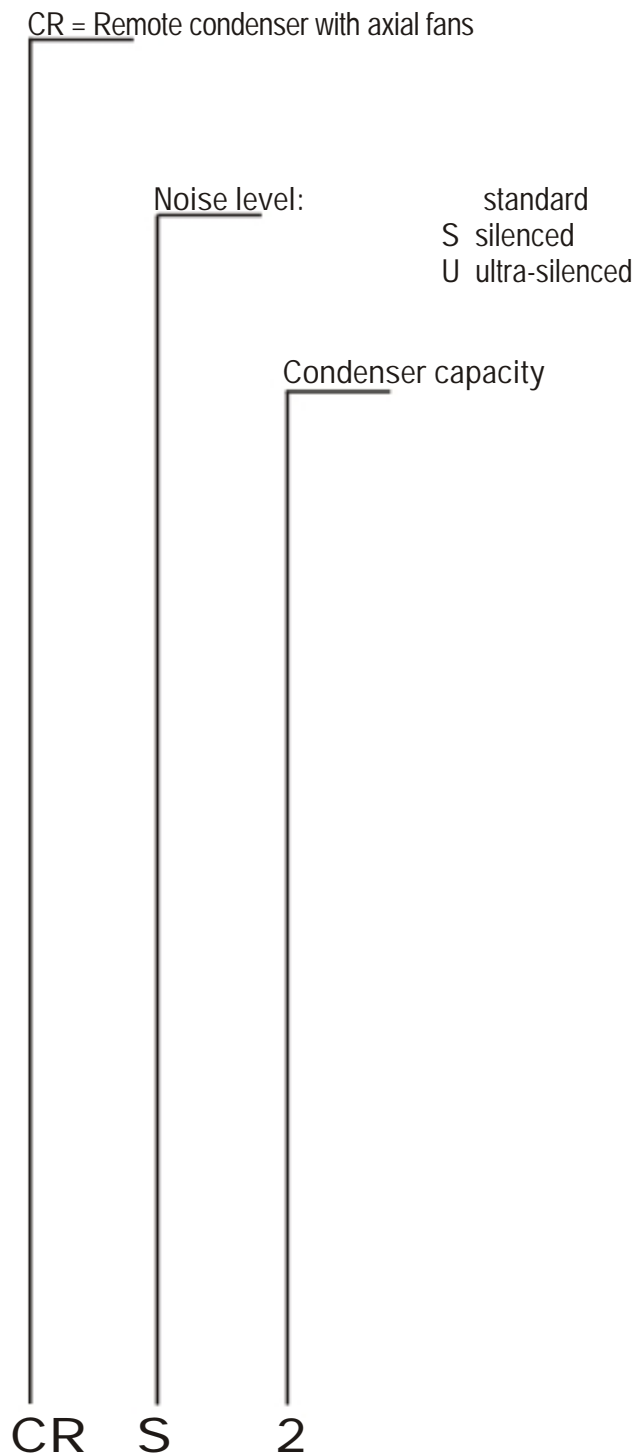

2 - TRANSPORTATION

During the transportation, avoid to press the packing improperly and always keep it in the position indicated on it.

Unpack the unit as close as possible to the place where it has to be installed. Once unpacked, avoid to hit the components.

During the air conditioner installation and handling, wear the appropriate gauntlets in order to avoid to be hurt by the unit cutting parts (ex. Fins).

3 - CHECKS FOR A CORRECT INSTALLATION



in order to avoid any damage during the lifting operation, use a beam and connect it to all available hooks as shown in Picture 1

- a) Make sure the floor and the structures can bear the unit weight;
- b) Do not install the unit in closed spaces;
- c) Leave an adequate free space to allow a correct air suction and discharge and an easy maintenance (see Par. 4.2);
- d) Make sure the condenser is properly fixed to the supporting floor;
- e) Check the electric power supply fits with the motor-fans characteristics;
- f) Condensers are equipped with axial motor-fans, therefore they are not appropriate for being ducted or for bearing higher available pressure;
- g) Make sure the operating conditions (temperature and pressure) are conform to the ones estimated in the plan;
- h) Make sure all electric connections are in compliance with existing local regulations;
- i) Only qualified personnel is allowed to have access to the unit for any required operation, in accordance with the laws in force;
- l) During the installation, suitable fixing and supporting systems for the unit must be foreseen.

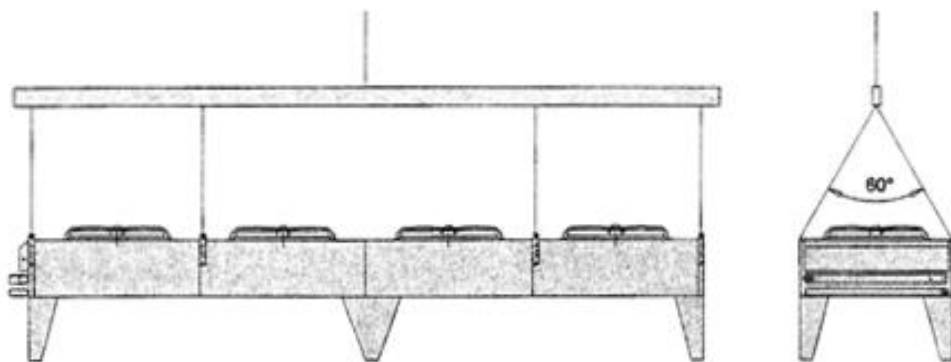

Pict. 1



Before any maintenance operation, make sure the electric power supply is disconnected from the main source: the electric parts might be connected to an automatic control.

4 - WARNINGS FOR A CORRECT PLACING

4.1 Technical specification

See the attached technical specification sheet.

4.2 Placing

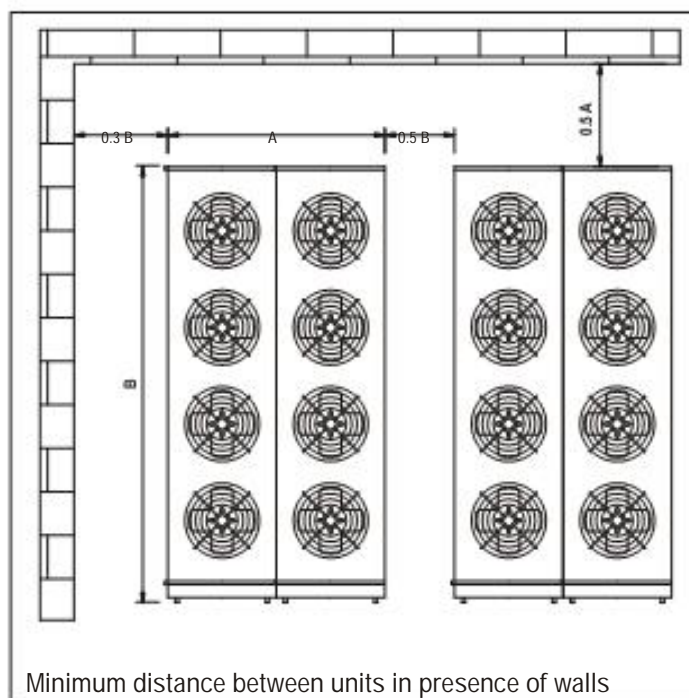
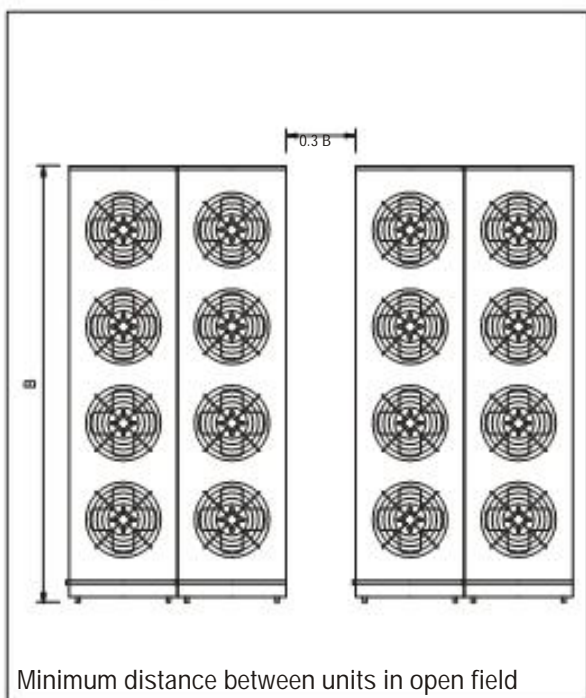
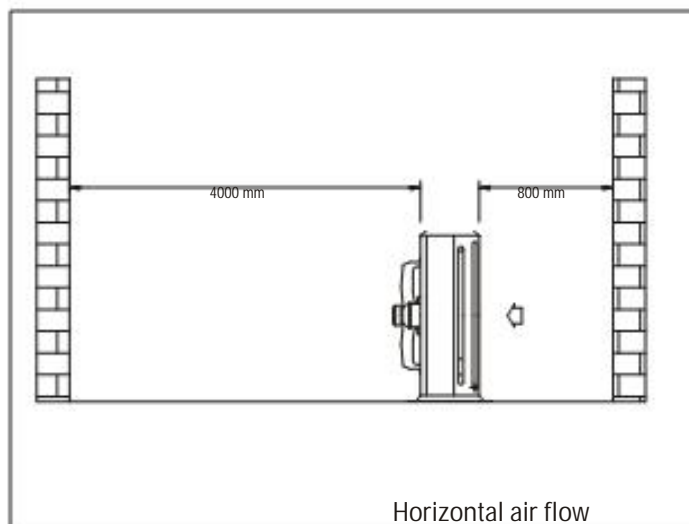
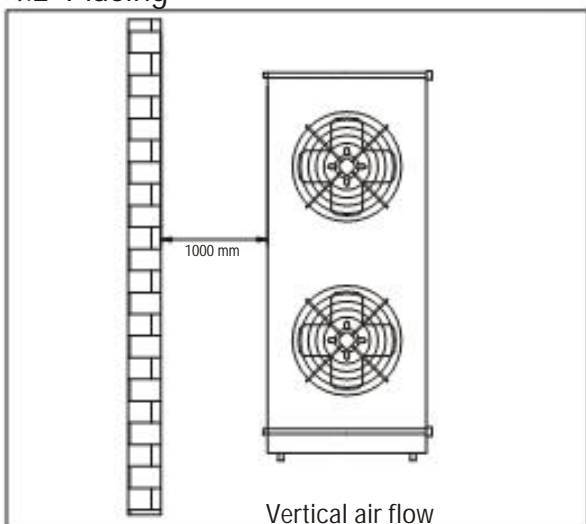

4.3 Electric connections

See the attached wiring diagram.

The thermal contacts are activated following the temperature and they are installed in the motors windings: when the temperature exceeds the maximum allowed permanent value, an electric contact is opened.

Carefully follow the attached wiring diagram to avoid any damage to the motor. Before employing an rpm regulation system, check if it is compatible with the motor: non-compatible systems can cause noise and damages. Emicon A. C. S.p.a. disclaims all responsibility for the performance of units equipped with a regulation system.

5 - INSTALLATION

For a correct installation, follow the tips here below:

- 1) Size properly the pipes in order to avoid as much as possible a pressure drop and a reduction of refrigerant speed, since both factors are essential for the oil drag. If necessary, an oil separator must be installed (3).
- 2) In case the discharge line goes through rooms where people normally live, install both a vibration damper (1) and a silencer (2) as close as possible to the compressor, on the discharge line.
- 3) Do not convey the air flow directly on a surface having a reflecting power or able to increase the condenser noise level.
- 4) Do not reverse for any reason the refrigerant inlet and outlet collectors.
- 5) Place the condenser preferably in a position where the coil has a minimum direct exposure to sun radiations since they could change the condensation pressure.
- 6) In all installations, make sure the airflow does not collide with other currents of air going in the opposite direction.
- 7) Strictly follow the local regulations in force.

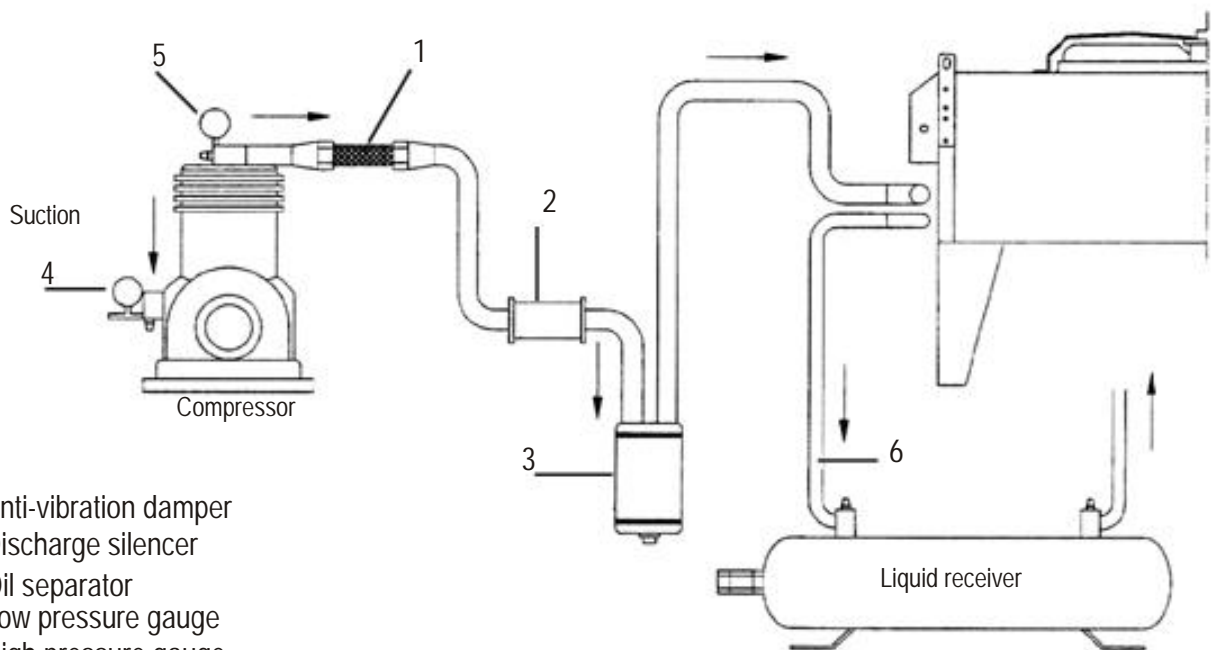

1. Anti-vibration damper
2. Discharge silencer
3. Oil separator
4. Low pressure gauge
5. High pressure gauge
6. A slope not lower than 1% must be foreseen between the outlet collector and the liquid receiver

The following table shows the necessary quantity of refrigerant for a correct charge of the different models of remote condensers.

CONDENSER MODEL			REFRIGERANT CHARGE
CR	CRS	CRU	
8	/	/	0,8 kg
11	7	/	1,5 kg
14	10	/	1,2 kg
18	13	/	1,8 kg
27	22	18	2,9 kg
30	25	20	3,8 kg
36	29	23	4,5 kg
45	/	28	6,0 kg
46	35	/	7,5 kg
49	42	32	5,7 kg
53	/	/	7,6 kg
59	57	43	9,0 kg
71	67	51	12 kg
90	85	68	14 kg
97	/	/	15 kg
/	99	74-87	18 kg
/	/	98	24 kg

6 - GENERAL MAINTENANCE

Check periodically the fasteners, the electric connections and the connections to the cooling system.

Clean periodically the unit to avoid any accumulation of harmful substances. It is advisable to use normal soapy water. Do not use solvents, aggressive, abrasive or ammoniac agents.



Only expert and qualified personnel can carry out the general maintenance.

DICHIARAZIONE CE DI CONFORMITÀ EC DECLARATION OF CONFORMITY CE-KONFORMITÄTSERKLÄRUNG DECLARATION CE DE CONFORMITÉ

Il Fabbricante

The Manufacturer

Der Hersteller

Le Fabricant

EMICON A.C. S.P.A.
 via A. Volta, 49
 47014 Meldola (FC)
 tel. (+39) 0543/495611
 fax. (+39) 0543/495612
 e-mail emicon@emiconac.it

DICHIARA
che la macchina
DECLARES
that the machinery
ERKLÄRT
daß die Einheit
DECLARE
que l'unité
Modello
Model
Modell
Modèle
Matricola
Serial Nr.
Seriennr.
N.ro de série
è conforme a tutte le disposizioni pertinenti delle direttive
2004/108/EC
in quanto è stata progettata, costruita e collaudata in accordo con le seguenti Norme

EN 61000-6-1
EN 61000-6-2
EN 61000-6-3
EN 61000-6-4

fulfils all the relevant provisions of the directives
2006/42/EC
because it has been designed, manufactured and tested according to the following Standards

EN ISO 12100-1
EN ISO 12100-2

den folgenden Vorschriften entspricht
da sie in Übereinstimmung mit den folgenden Normen geplant gebaut und getestet wurde
est conforme aux dispositions
2006/95/EC
étant l'appareil conçu, réalisé et testé dans le respect des normes suivantes

EN 60204-1
EN 60335-1
EN 60335-2-40
EN 60439-1

AUTORIZZA
a costituire il Fascicolo Tecnico.
AUTHORISES

Romano Santucci
 via A Volta, 49
 47014 Meldola (FC)

to compile its Technical File.
AUTORISIERT
die technischen Unterlagen zu erstellen
AUTORISE
à réaliser le dossier technique.

Meldola, ___/___/_____

Romano Santucci

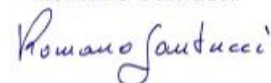

Technical Manager

EMICON A.C. S.p.a. – Via A. Volta, 49 – 47014 Meldola (FC) Italy – P.IVA IT 03402390409

Reg. Imprese di Forlì-Cesena n. 03402390409 – REA n. 299199

Capitale sociale € 800.000,00 i.v.

 Tel. (39) 0543 495611 – Fax (39) 0543 495612 – E-mail: emiconac@emiconac.it

Emicon A.C. S.p.a. reserves the right to make changes to tis products without any prior notice



Emicon A.C. S.p.a. Via A.Volta 49 Meldola Tel. +39 0543 495611 Fax +39 0543 495612